

Beechcraft®

Travel Air

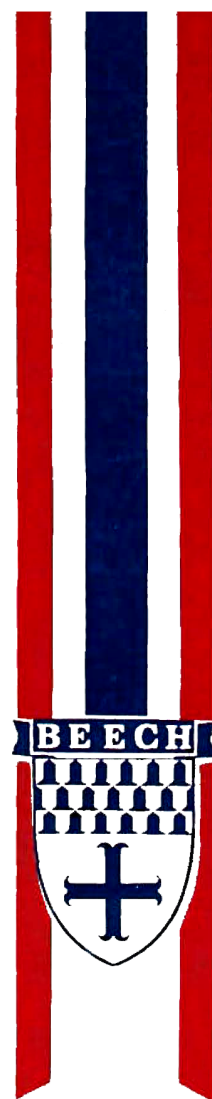

MODEL **D95A**

**OWNER'S MANUAL**

Beech Aircraft Corporation  Wichita, Kansas



# Beechcraft

## Travel Air

### D95A

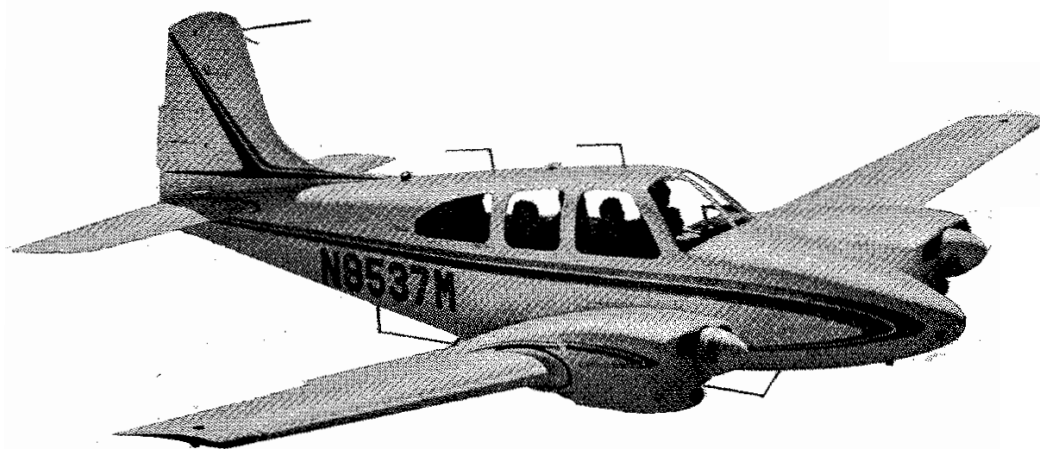

PUBLISHED BY  
PARTS AND SERVICE OPERATIONS  
BEECH AIRCRAFT CORPORATION  
WICHITA, KANSAS

95-590014-61  
Issued June 12, 1963

95-590014-61A<sub>1</sub>  
Revised August 3, 1964

## *OWNER'S MANUAL*

## LIST OF EFFECTIVE PAGES

TOTAL NUMBER OF PAGES IN THIS BOOK IS 132

*Title	A1	August 3, 1964
*List of Effective Pages	A1	August 3, 1964
i through vi		Original
*1-9 through 1-10B	A1	August 3, 1964
1-11 through 1-21		Original
2-1 through 2-2		Original
*2-3 through 2-4A	A1	August 3, 1964
3-1 through 3-6		Original
4-1 through 4-2		Original
*4-3 through 4-4	A1	August 3, 1964
4-5 through 4-18		Original
5-1 through 5-13		Original
6-1 through 6-23		Original
7-1 through 7-4		Original
*7-5 through 7-6A	A1	August 3, 1964
7-7 through 7-9		Original
*7-10	A1	August 3, 1964
7-11 through 7-15		Original
*7-16	A1	August 3, 1964
7-17 through 7-30		Original

*\*The asterisk indicates pages revised, added or deleted  
by the current revision.*

## **THANK YOU . . .**

for displaying confidence in us by selecting a BEEHCRAFT airplane. Our design engineers, assemblers and inspectors have utilized their skills and years of experience to ensure that the new BEEHCRAFT meets the high standards of quality and performance for which BEEHCRAFT airplanes have become famous throughout the world.

### **IMPORTANT NOTICE**

This manual should be read carefully in order to become familiar with the operation of the airplane. Suggestions and recommendations have been made within it to aid in obtaining maximum performance without sacrificing economy. Be familiar with and operate the airplane in accordance with the Owner's Manual and FAA Approved Airplane Flight Manual and/or placards which are located in the airplane.

As a further reminder, the owner and operator should also be familiar with the Federal Aviation Regulations applicable to the operation and maintenance of the airplane, and FAR Part 91 General Operating and Flight Rules. Further, the airplane must be operated and maintained in accordance with FAA Airworthiness Directives which may be issued against it.

The Federal Aviation Regulations place the responsibility for the maintenance of this airplane on the owner and the operator, who should make certain that all maintenance is done by qualified mechanics in conformity with all airworthiness requirements established for this airplane.

All limits, procedures, safety practices, time limits, servicing, and maintenance requirements contained in this manual are considered mandatory for continued airworthiness to maintain the airplane in a condition equal to that of its original manufacture.

Authorized BEEHCRAFT Parts and Service Outlets will have recommended modification, service, and operating procedures issued by both FAA and Beech Aircraft Corporation, which are designed to get maximum utility and safety from the airplane.

# ***Table of Contents***

**SECTION I Descriptive Information .....1-1**



**SECTION II Operating Check Lists .....2-1**



**SECTION III Performance Specifications  
and Limitations .....3-1**



**SECTION IV Flying Your BEEHCRAFT .....4-1**



**SECTION V Unusual Operating Conditions ....5-1**



**SECTION VI Operational Data .....6-1**



**SECTION VII Servicing and Maintenance .....7-1**



# General Specifications

## ENGINES

Two Lycoming, 4-cylinder, IO-360-B1B, rated at 180 hp @ 2700 rpm for all operations.

## PERFORMANCE — TRUE AIRSPEED, STANDARD ALTITUDE

### MAXIMUM CRUISING SPEED:

(a), at 75% power (2450 rpm) ..... 200 mph/174 kts  
at 7500 ft.

(b) at 65% power (2450 rpm) ..... 195 mph/169 kts  
at 11,000 ft.

### HIGH SPEED AT SEA LEVEL

(2700 rpm, full throttle) ..... 210 mph/182 kts

### RATE OF CLIMB AT SEA LEVEL (rated power)

Two engines ..... 1250 fpm

One engine ..... 205 fpm

### SERVICE CEILING (rated power) @ 4200 pounds

Two engines (100 fpm) ..... 18,100 ft.

One engine (50 fpm) ..... 4400 ft.

### ABSOLUTE CEILING @ 4200 pounds

Two engines ..... 19,800 ft.

Single engine (descending to level out at) ..... 5850 ft.

STALLING SPEED (Zero Thrust), Flaps 28°, Gear Down ..... 70 mph/61 kts

MAXIMUM RANGE @ 165 mph/143 kts ..... 1170 miles on 112 gal.\*

ENDURANCE ..... 7.54 hours\*

TAKE-OFF DISTANCE — (20° flap) Ground Run ..... 1000 ft.\*\*

Total Distance over 50 ft. .... 1280 ft.\*\*

LANDING DISTANCE — (28° flap) Ground Run ..... 980 ft.\*\*

Total Distance over 50 ft. .... 1590 ft.\*\*

The above performance figures are the results of flight tests of the Travel Air conducted by Beech Aircraft Corporation under factory-controlled conditions and will vary with individual aircraft and numerous factors affecting flight performance.

\*Includes warm-up, taxi, take-off, climb and 45 minutes holding at 45% MC power.

\*\*Take-off and landing performance based on Sea Level Standard Conditions.

## TYPE

Four or five-place, high-performance, all-metal, low-wing, twin-engine cantilever monoplane, with fully retractable tricycle landing gear, solid cabin top, and full complement of engine and flight instruments standard.

## BAGGAGE

Maximum 400 pounds — rear

270 pounds less equipment — front

## WEIGHTS

Gross Weight ..... 4200 lbs.

Empty Weight, Dry (Approx.) ..... 2555 lbs.

(Empty weight includes complete set of flight instruments; cabin heating and venti-

ating system with windshield defrosters; soundproofing; navigation, cabin, instrument and landing lights.)

Useful Load (Approx.) ..... 1645 lbs.

## WING AREA AND LOADINGS

Wing Area ..... 199.2 sq. ft.  
Wing Loading, at gross weight ..... 20.6 lbs./sq. ft.  
Power Loading, at gross weight ..... 11.4 lbs./hp

## DIMENSIONS

Wing Span ..... 37 ft. 10 in.  
Length ..... 25 ft. 11 in.  
Height ..... 9 ft. 6 in.

## CABIN DIMENSIONS

Cabin Length ..... 8 ft. 6 in.  
Cabin Width ..... 3 ft. 6 in.  
Cabin Height ..... 4 ft. 2 in.  
Passenger Door size ..... 36 in. x 37 in.  
Baggage Door size, rear ..... 18.5 in. x 22.5 in.  
Baggage Compartment size, rear ..... 33.5 cubic ft.  
Baggage Compartment size, front ..... 12 cubic ft.  
Accessory Shelf, nose cone ..... 7 cubic ft.

## PROPELLER AND EQUIPMENT

Propeller — constant speed, full feathering, diameter 72", with hydraulic governor.

## ENGINE EQUIPMENT (Per Engine)

Starter  
Generator  
Voltage Regulator  
Auxiliary Fuel Pump  
Induction Air Filter  
Exhaust Manifolds (stainless steel)  
Vacuum Pump

## FUEL AND OIL CAPACITY

Fuel Capacity in standard wing tanks ..... 80 gal. (usable)  
Fuel Capacity with optional auxiliary wing tanks ..... 112 gal. (usable)  
Oil Capacity ..... 16 quarts

## LANDING GEAR

Tricycle type with swiveling steerable nose wheel equipped with shimmy dampener. Beech air-oil struts on all wheels designed for smooth taxiing and to withstand the shock created by landing with a vertical descent component of over 600 feet per minute. Main tires 7.00" x 6" size; nose wheel tire 5.00" x 5" size. Wheels — Beech with ring-disc hydraulic brakes.

## ELECTRICAL EQUIPMENT (24 Volt System)

One 17-ampere-hour battery, standard (two 24-ampere-hour batteries, optional); electric motors for operating flaps and landing gear; electrically operated cowl flaps (optional); two 25-ampere generators, standard (two 40-ampere generators, optional).



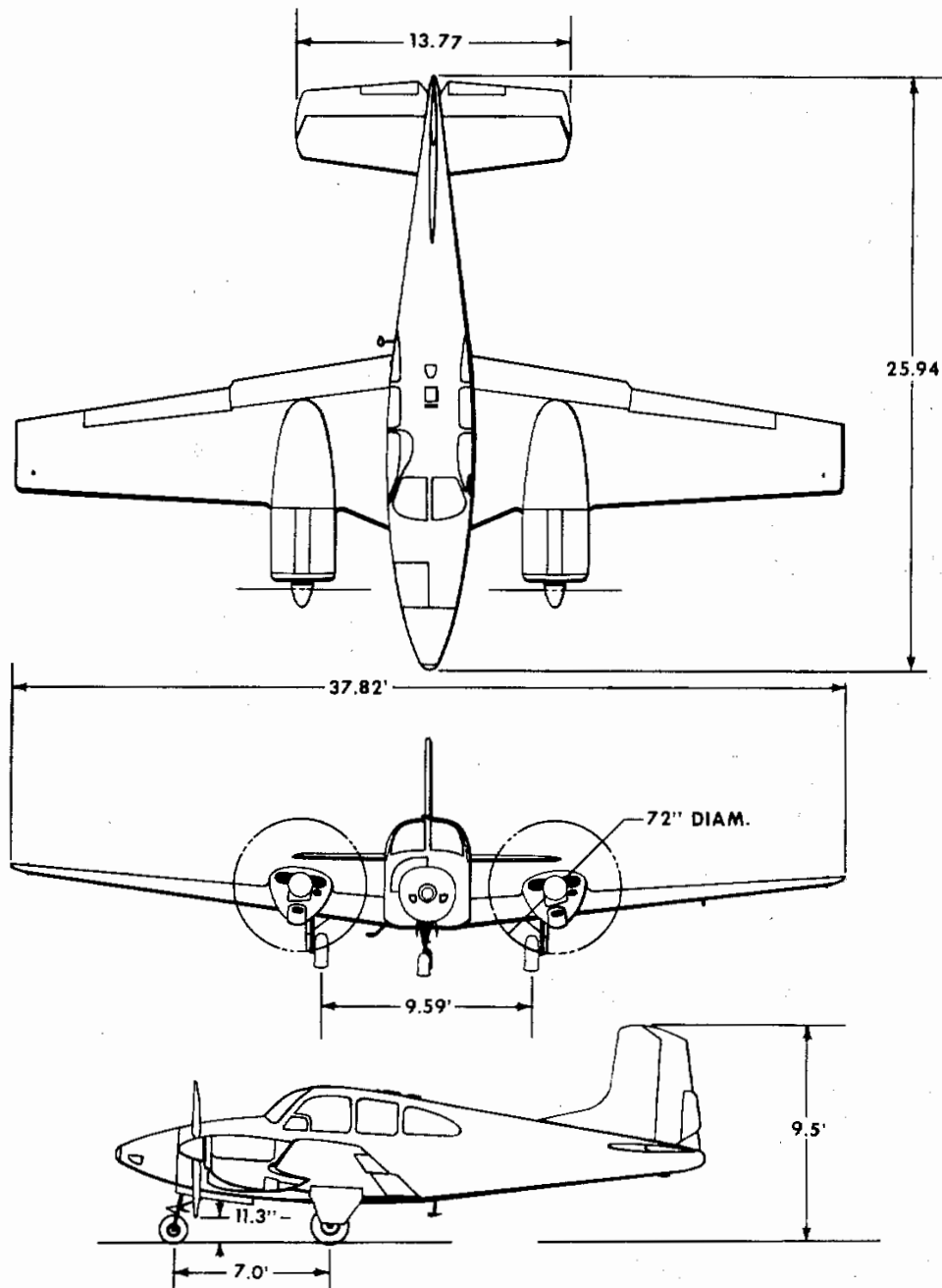

## **SECTION I**

# ***Descriptive Information***

Your new BEEHCRAFT Travel Air is a four or five-place, low wing monoplane. The all-metal, semimonocoque airframe structure is of aluminum, magnesium and alloy steel, riveted and spotwelded for maximum strength. Careful workmanship and inspection make certain that structural components will withstand flight loads in excess of the FAA requirements for a "Normal" category, under which the Model D95A is licensed.

To develop a good flying technique, you must first have a general working knowledge of the several systems and accessories of your aircraft. Although they are closely interdependent in fact, these systems have been broken down arbitrarily in this section for ease of presentation.

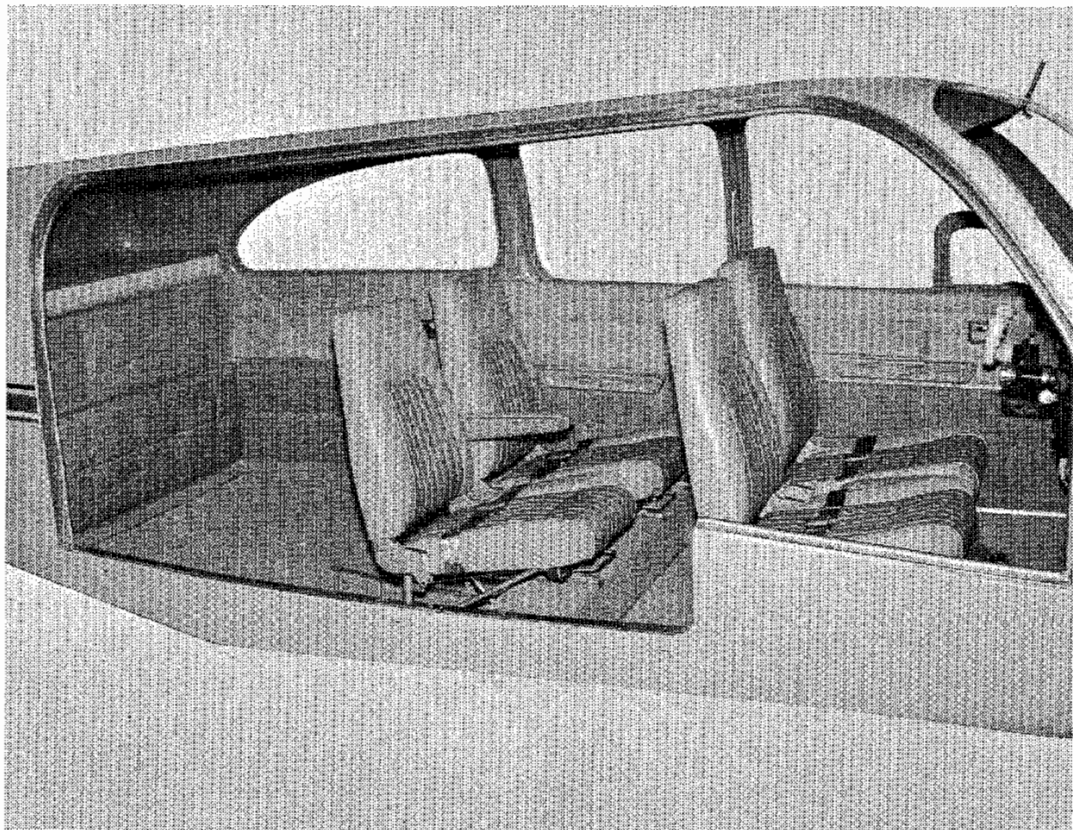

## **FLIGHT CONTROLS**

Primary movable control surfaces of the Travel Air are operated through push-pull rods and conventional closed-circuit cable systems terminating in bell cranks. The pre-formed, extra-flexible steel cables run over phenolic pulleys with sealed ball bearings which ordinarily require no lubrication and insure smooth, free action and long cable life. Standard equipment provides a throw-over type control wheel arm for elevator and aileron control which may be locked in position on either the pilot or copilot side and pilot's rudder pedals adjustable fore and aft to fit individual requirements. The right hand rudder pedals (optional) may be laid flat against the floorboards when not in use. Trim tabs on the elevator and rudder control surfaces are adjustable from the control console through closed-circuit cable systems which drive jackscrew type actuators. Position indicators for each of the trim tabs are located near the respective controls. Aileron trim is accomplished by actuating the aileron trimmer on the control column hub. The trimmer displaces the aileron surfaces themselves to compensate for uneven loading. The displacement is maintained by cable loads imposed by the aileron trimmer.

Single, slot-type wing flaps are operated through a system of flexible shafts and jackscrew actuators driven by a reversible electric motor located under the front seat. The flap position lights on the left side of the control console show green for the up position and red for the full down ( $28^{\circ}$ ) landing position. Intermediate flap positions of  $10^{\circ}$  and  $20^{\circ}$ , as marked on the leading edge of the left flap, may be selected by moving the three position control switch on the left side of the console to "OFF" when the desired flap setting mark lines up with the wing trailing edge. Limit switches automatically shut off the flap motor when the full up or down position is reached.

## **LANDING GEAR**

The Travel Air's extra strong, electrically operated tricycle landing gear incorporates all of the advantages provided by this type gear. The ease of ground operation is assisted by the increased visibility, more positive directional control for parking or operation under high surface wind conditions, decreased stopping distance and longer brake and tire life; these are but a few of the advantages.

The gear is operated through push-pull tubes by a reversible electric motor and actuator gear box under the front seat. The motor is controlled by a two-position landing gear switch located on the right hand side of the control console. Limit switches and a dynamic braking system automatically stop the retract mechanism when the gear reaches its full up or full down position.

With the landing gear in the up position, the wheels are completely enclosed by fairing doors which are operated mechanically by the retraction and extension of the gear. After the gear is lowered, the main gear inboard fairing doors automatically close, producing extra lift and reduced drag for take-off and landing. Individual uplocks actuated by the retraction system lock the main gear positively in the up position. No downlocks are necessary since the over-center pivot of the linkage forms a geometric positive lock when the gear is fully extended. The linkage is also spring loaded to the over-center position.

Landing gear position lights, located above the landing gear switch, indicate the position of the gear, either up or down, coming on only when the gear reaches its fully extended or retracted position. In addition, a mechanical indicator beneath the control console shows the position of the nose gear at all times.

To prevent accidental gear retraction on the ground, a safety switch on the left main strut breaks the control circuit whenever the strut is compressed by the weight of the airplane and completes the circuit so the gear may be retracted, when the strut extends. ***Never rely on the safety switch to keep the gear down while taxiing or on take-off or landing roll. Always check the position of the switch handle.***

With the gear retracted, if either or both throttles are retarded below an engine setting sufficient to sustain flight, a warning horn will sound an intermittent note. During single-engine operation the horn may be silenced by advancing the throttle of the inoperative engine enough to open the landing gear warning horn switch.

The nose wheel assembly is made steerable through spring loaded linkage, connected to the rudder pedals for greater maneuverability during taxi operation. The retraction of the gear relieves the rudder pedals of their nose steering load and centers the wheel, by a roller

and slot arrangement, to insure proper retraction into the wheel well. A hydraulic dampener on the nose wheel strut compensates for the inherent shimmy tendency of a pivoted nose wheel.

Wheels are carried by heat treated tubular steel trusses and use Beech air-oil type shock struts. Since the shock struts are filled with both compressed air and hydraulic fluid, their correct inflation should be checked prior to each flight. Even brief taxiing with a deflated strut can cause severe damage.

For manual operation of the landing gear (lowering only) a handcrank is located behind the front seats. The crank, when engaged, drives the normal gear actuation system.

Main landing gear wheels are equipped with BEEHCRAFT ring-disc, self-adjusting, self-energizing hydraulic brakes actuated by individual master cylinders connected to the rudder pedals and operated as toe brakes. The hydraulic brake fluid reservoir is accessible from the forward baggage compartment and should be checked occasionally for specified fluid level. The parking brake is set by a push-pull control with a center-button lock and is located just to the left and slightly below the control console. Setting the control does not pressurize the brake system, but simply closes a valve in the lines so that pressure built up by pumping the toe pedals is retained and the brakes remain set. Pushing the control in opens the valve and releases the brakes.

## **POWER PLANTS**

Your Travel Air is powered by two Lycoming IO-360-B1B engines rated at 180 horsepower each, at 2700 rpm, for take-off and maximum continuous operation. The four-cylinder, opposed, aircooled engines have direct propeller drives and a compression ratio of 8.5:1. Pressure type cowlings are used; cooling is controlled by a gill-type flap on the lower trailing edge of each cowling. Fuel distribution is accomplished with a constant-flow fuel injection system which incorporates a special aerated nozzle at the intake port of each cylinder. Filtered induction system air is obtained through a filtered airscoop on the lower front of the engine and directed to the air throttle valve. A spring loaded door on the bottom of the air box opens automatically if the airscoop is blocked by impact ice or dirt. Manual controls on the control console may be used to select either filtered or alternate air. Full dual ignition systems are used, with an ignition vibrator

supplying starting voltage. The electrical system uses Delco-Remy starters, generators, and voltage regulators. Fuel injection pumps, vacuum pumps, and constant-speed propellers are standard equipment. Other features include sodium-cooled rotator-type valves, chrome piston rings and a nitrided crankshaft.

Constant-speed, two-bladed, hydraulic, full feathering propellers use pressure from a feathering spring and centrifugal force from the blade shank counterweights to increase pitch. Engine oil under governor-boosted pressure decreases pitch.

Propeller feathering is accomplished by pulling the propeller control back past the detent to the limit of travel. Unfeathering and restarting is achieved by moving the propeller control well into the governing range and following the normal starting procedure. On airplanes with the optional unfeathering accumulator, momentary use of the starter to initiate rotation is necessary only at low airspeeds. Immediately after the engine starts, the throttle and propeller controls should be adjusted to prevent an engine over-speed condition.

### **Power Plant Controls**

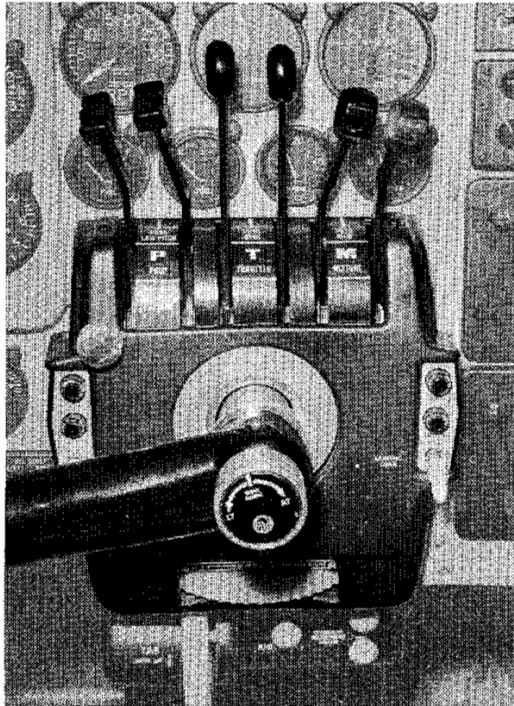

Propeller, throttle and mixture control levers, grouped along the upper face of the control console, are within easy reach of the pilot. Their knobs are shaped to government standard configuration so they may be identified by touch.

The levers are connected to their respective units by flexible control cables routed through the leading edge of each wing. A controllable friction lock on their support shaft may be tightened once power settings are established, to prevent creeping. Controls for the alternate air are hand-operated, push-pull type with center-button

locks, and are mounted on the lower face of the control console.

Direct-cranking electric starters are relay-controlled and are energized by spring loaded, combination magneto-starter switches, located on the ignition panel. These spring loaded switches return to the "BOTH" position when released. The push-pull, button-lock type controls that operate the engine cowl flaps are located aft of each fuel selector valve handle. The optional electrically operated cowl flaps are controlled by switches on the electrical panel located to the left of the control console. An indicator light adjacent to the switches comes on whenever the electric cowl flaps are not fully closed.

## **Fuel System**

The Travel Air's fuel system consists of a separate, identical supply for each engine, interconnected by crossfeed lines for emergency use. During normal operation each engine uses its own fuel pumps to draw fuel from its respective fuel cell arrangement. However, on crossfeed operations the entire fuel supply of any or all cells may be consumed by either engine. A fuel selector valve for each engine controls the cells from which fuel is used.

The standard fuel cell arrangement consists of one 40-gallon fuel cell in the inboard portion of each wing leading edge. Total fuel capacity for this system is 80 gallons of usable fuel. With an optional fuel cell arrangement of one 25-gallon main fuel cell in each wing leading edge and one 31-gallon auxiliary cell just aft and outboard of each main cell, the total capacity is raised to 112 gallons of usable fuel. Fuel cannot transfer from one cell to another during flight.

Fuel quantity is measured by a float-type transmitter unit in each cell, which transmits a signal to the fuel gages on the instrument panel. When the optional 112-gallon installation is used, a two-position switch determines the cell, main or auxiliary, to which the gage is connected. Each cell is filled through its own filler neck with openings in the upper wing surface and sealed with flush-type filler caps.

An electric auxiliary fuel pump for each engine supplies fuel pressure for starting and provides for near maximum engine performance should the engine-driven pump fail. The auxiliary fuel pumps are used for starting and emergencies, and may be used for take-off and landing. In extremely hot weather they should be employed for all ground operations, take-off, climb, and landing. Due to the in-line location of the

# FUEL SYSTEM SCHEMATIC

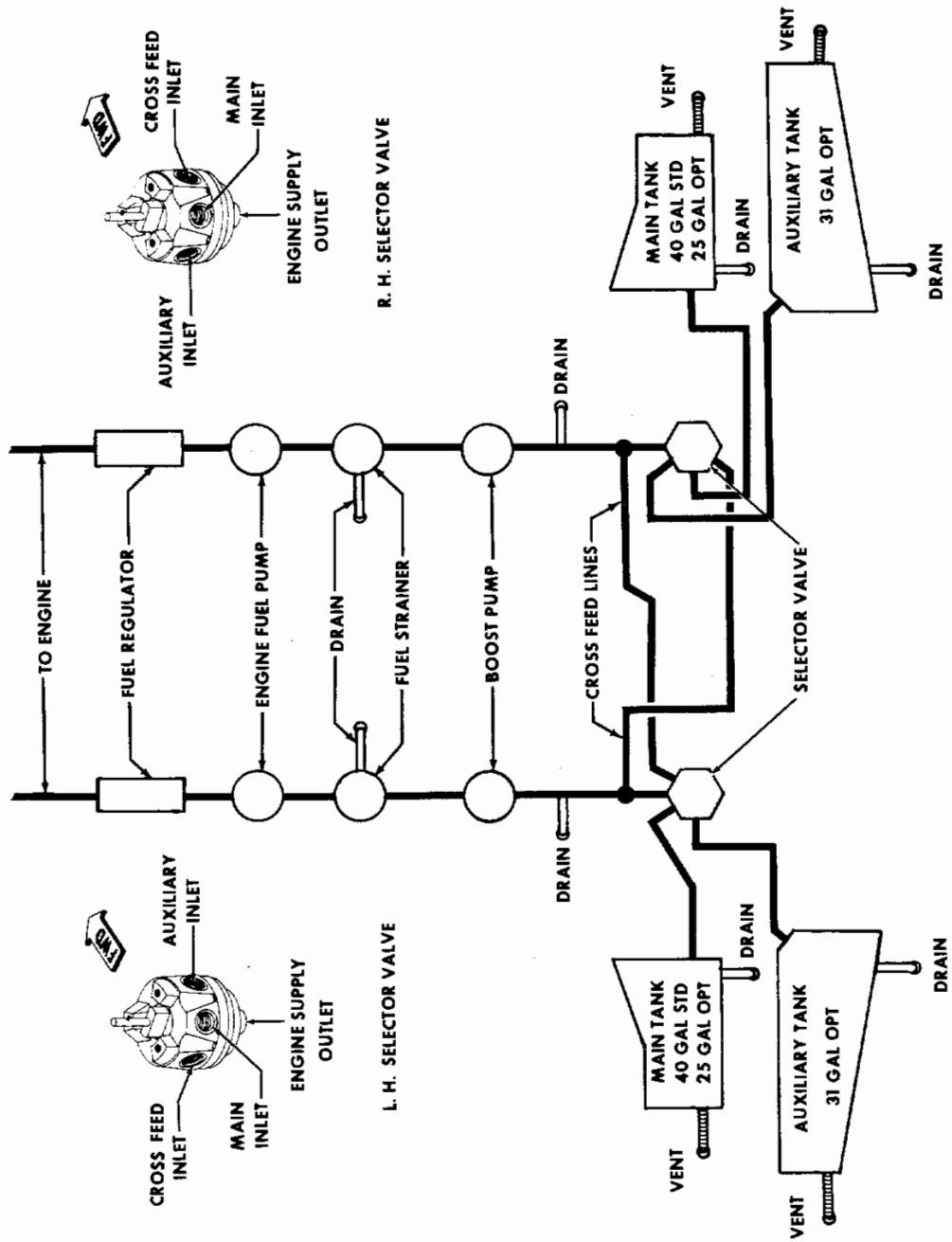



auxiliary fuel pumps, between the cells and metering unit, fuel may be drawn from any cell within the system by the auxiliary pump for the operating engine. The fuel system is drained at eight different locations (including the two optional auxiliary cell sumps) as shown in the fuel system schematic and the servicing diagram. Fuel system strainers are located on the wing main spar in each wheel well and at the inlet to the fuel control units. Regular checking of the strainers is of utmost importance to preventive maintenance, since lowered fuel pressure may often be traced to contaminants clogging the system.

A fuel flow indicator on the instrument panel is calibrated in gallons per hour, based on system pressure at the fuel manifold valve of the fuel injection unit. The instrument also indicates fuel pressure for starting.

### **Oil System**

The engine oil system is of the full-pressure, wet-sump type and has an 8-quart capacity. For safe engine operation, the absolute minimum amount of oil required in the sump is 2 quarts. Oil operating temperatures are controlled by an automatic thermostat by-pass control incorporated in the engine oil passage of each system. The automatic by-pass control will prevent oil flow through the cooler when operating temperatures are below normal. It also will by-pass if the radiator is blocked. System servicing and draining points are shown on the servicing diagram. The determining factor for choosing the correct grade of oil is the oil inlet temperature which is observed during flight; inlet temperatures consistently near the maximum allowable would indicate a heavier oil is needed. Straight petroleum base, aviation grade, nondetergent oil of the lightest weight that will provide adequate cooling should be used. Certain additive type aviation grade oils are also approved by the engine manufacturer, but they should be used with caution. (See servicing information and Consumable Materials Chart in Section VII.) Condensed moisture in the oil sump may be drained by occasionally opening the oil drain valve and allowing a small amount of oil to escape; ideally, this draining should be done when the engines have been stopped overnight or approximately 12 hours. This procedure should be followed more closely during cold weather or when a series of short flights of less than 30 minutes duration have been made and the engines allowed to cool completely between such flights.

### **INSTRUMENTS**

All flight and engine instruments are positioned on the instrument panel

for maximum utility and convenience. Instrument markings are matte white on a black background and where practicable, the normal operating limits are indicated.

The flight instruments are located on a hinged floating panel directly in front of the pilot's seat. Standard flight instrumentation includes attitude and directional gyros, airspeed, altimeter, rate-of-climb, electric turn-and-bank, and a clock. The airspeed indicator is marked with a special blue line range for single-engine operation. An outside air temperature thermometer and magnetic compass are mounted on the windshield divider.

The standard engine instruments consist of the dual manifold pressure gage and individual tachometers with engine hour recorders at the top center of the instrument panel, the dual fuel flow indicator on the lower

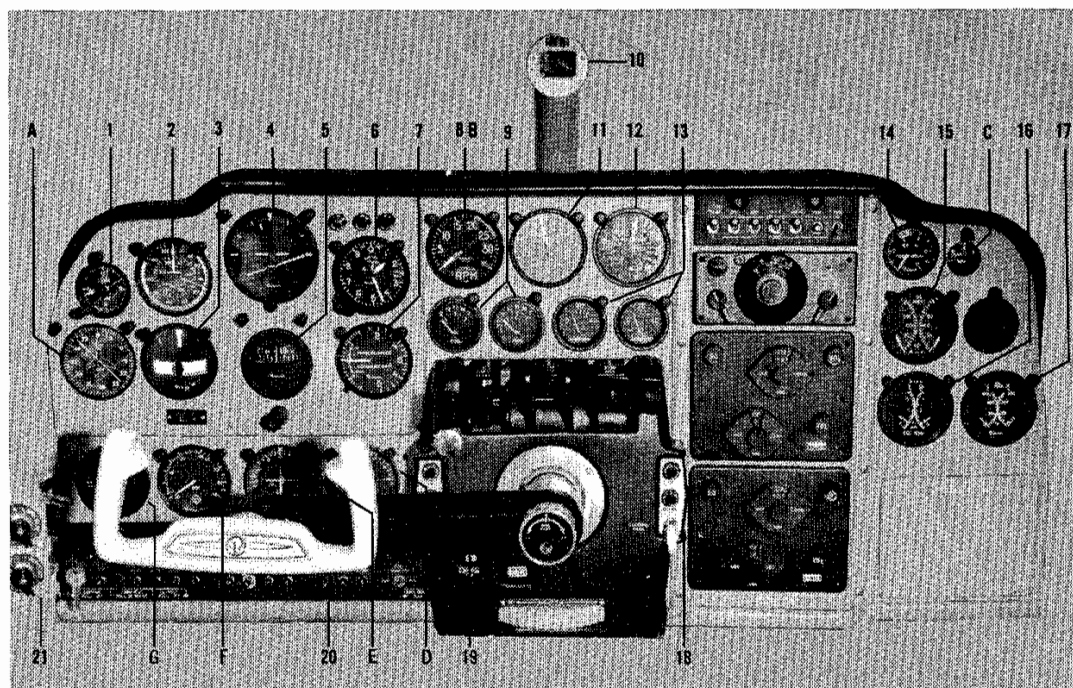

#### STANDARD EQUIPMENT

1. Clock
2. Airspeed Indicator
3. Turn-and-Bank Indicator
4. Attitude Gyro
5. Directional Gyro
6. Altimeter
7. Vertical Speed Indicator
8. Tachometer
9. Fuel Quantity Gages
10. Magnetic Compass
11. Dual Manifold Pressure Gage

12. Dual Fuel Flow Indicator
13. Ammeters
14. Suction Gage
15. Dual Oil Pressure Gage
16. Dual Cylinder Head Temperature Gage
17. Dual Oil Temperature Gage
18. Landing Gear Position Switch
19. Flap Position Switch
20. Electrical Panel
21. Ignition Panel and Generator or Alternator Switches

#### OPTIONAL EQUIPMENT

- A. ADF Indicator
- B. Dual Tachometer
- C. Propeller Anti-Icer Fluid Gage
- D. VOR Indicator
- E. VOR Indicator with Glide Slope
- F. DME Indicator
- G. DME Control

left hand side of the panel, and the dual oil temperature, oil pressure, and cylinder head temperature gages plus a suction gage on the right hand side of the panel. When the optional dual tachometer is installed, the fuel flow indicator is mounted adjacent to the manifold pressure gage in the top center portion of the panel. Fuel quantity is shown by two separate gages, each gage serving both the standard and the optional fuel tank in each wing. The gages are mounted with the ammeters just above the control console.

Impact air pressure and atmospheric air pressure for the airspeed indicator, altimeter, and vertical speed indicator are supplied by the pitot and static air systems. Since the accuracy of these instruments depends on accurate pickup of the two pressures, the systems have been developed carefully and tested in flight with highly accurate special equipment. To insure the proper operation of these instruments, drain the systems regularly and keep the static ports clear of obstructions.

## **ELECTRICAL SYSTEM**

The Travel Air's direct-current electrical power system uses either, one 17-ampere-hour 24-volt battery, or two 25-ampere-hour 12-volt batteries, in any standard or optional combination with two 25-ampere 12-volt generators, or two 50-ampere alternator rectifiers. Either battery installation is mounted in the lower portion of the nose section; both generator installations are belt driven from the engine crankshaft. In general, the aircraft's circuitry is the single-wire, ground-return type with the aircraft structure itself being used as the ground return.

On the standard generator installation, each generator's electrical out-put is automatically controlled by its respective voltage regulator and the system's common generator paralleling relay. This paralleling relay equalizes the out-put or load for each generator. The system electrical reading is then indicated on the direct reading type (not the charge-discharge type) ammeters located on the instrument panel just above the control console. These ammeters indicate individual generator out-put and also serve as system load-meters, i.e., an ammeter indication will increase or decrease in direct proportion to the electrical load applied.

On the optional, or alternator installation, both alternators are controlled by two fully transistorized electronic voltage regulators, however,

only one regulator is operable in the system at a time; the remaining regulator being used as an alternate or standby. Either of these regulators when switched into the circuit will automatically adjust alternator output to the required electrical load, including battery recharging. These electronic voltage regulators provide usable current output at low engine rpm. Each alternator will produce approximately 20 amperes at 1100 engine rpm. Selection of a regulator is made by a select switch placarded 1 and 2, located on the ignition switch panel.

System protection against overvoltage is provided by an overvoltage relay which disconnects the alternators from the aircraft bus should an overvoltage condition occur. A press-to-test overvoltage warning light located on the instrument panel illuminates whenever the alternator is disconnected from the aircraft bus by the overvoltage relay. Should an overvoltage condition occur (illumination of overvoltage warning light), switch to the standby voltage regulator, either 1 or 2 as necessary. Should the condition persist, pull the alternator field circuit breaker (5-ampere) and correct the discrepancy prior to the next flight. Illumination of this light provides a warning that electrical current consumption should be minimized since only battery power is available with the alternators shut-off. The circuit is also designed so that the alternators are automatically shutoff whenever the battery master switch is OFF.

### CAUTION

To protect the alternators from overheating, do not use more than 45 amperes from either alternator while operating on the ground at temperatures above 100° F (38° C) or in flight at altitudes above 14,000 feet with outside air temperature above 45° F (70° C).

A panel containing the magneto, starter, battery, and generator switches is located below the pilot's storm window. On aircraft equipped with alternator generators, this panel is modified by replacing the generator switches with alternator control switches and the addition of a regulator 1 and 2 switch and a 5-ampere alternator field circuit breaker. Placards indicate the particular circuit controlled by the electrical switches and individual circuit breakers in the panel to the left of the control console. Refer to Section VII for alternator servicing and maintenance information.

# ELECTRIC POWER DISTRIBUTION

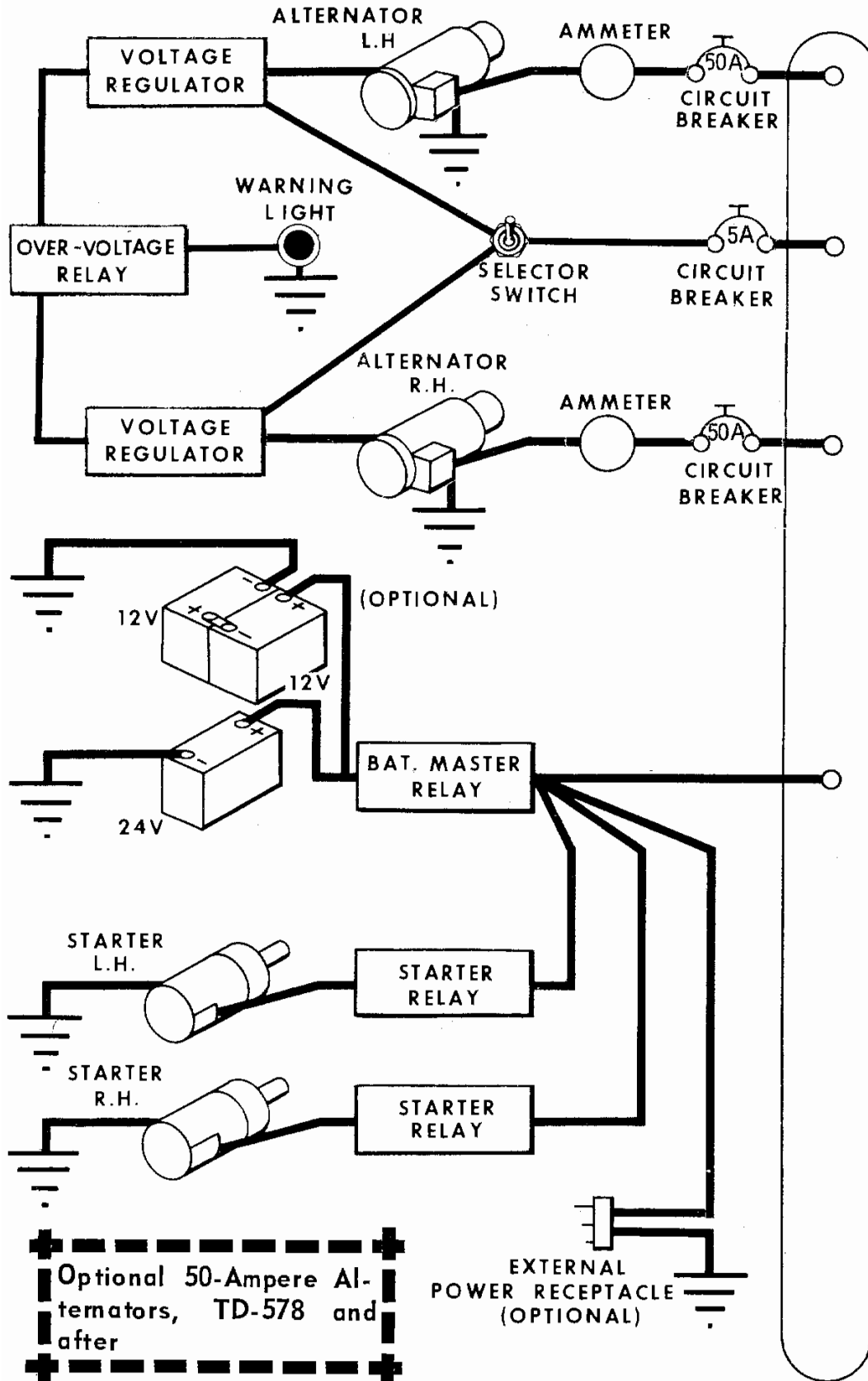

# ELECTRIC POWER DISTRIBUTION

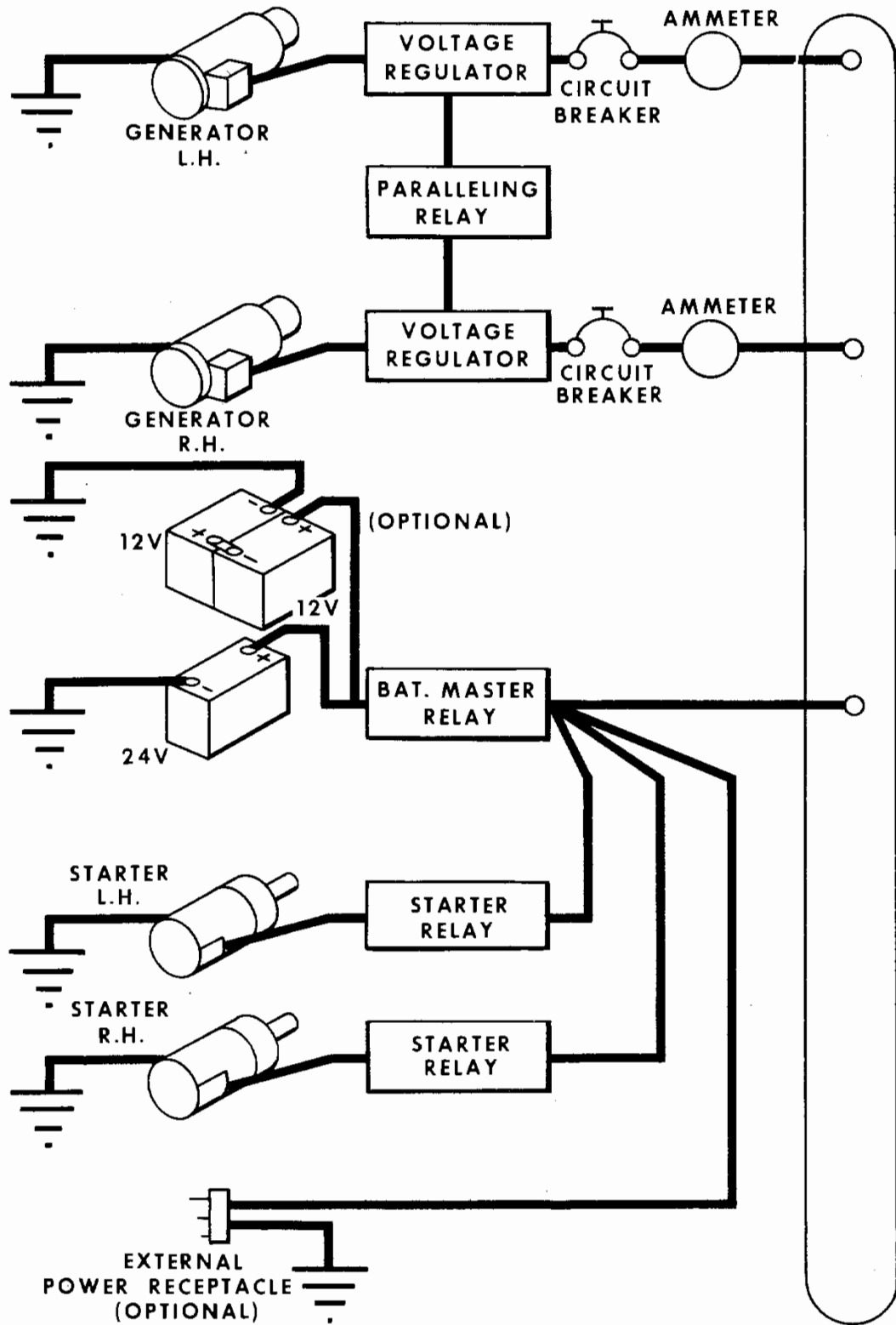

The automotive-type starters are relay-controlled, which minimizes the length of heavy cable required to carry the high amperage of the starter circuit. A drive unit actuated by centrifugal force from the operating starter motor engages and rotates the external ring gear at the front of the engine crankcase. When the starter motor is de-energized, the drive disengages from the ring gear pinion.

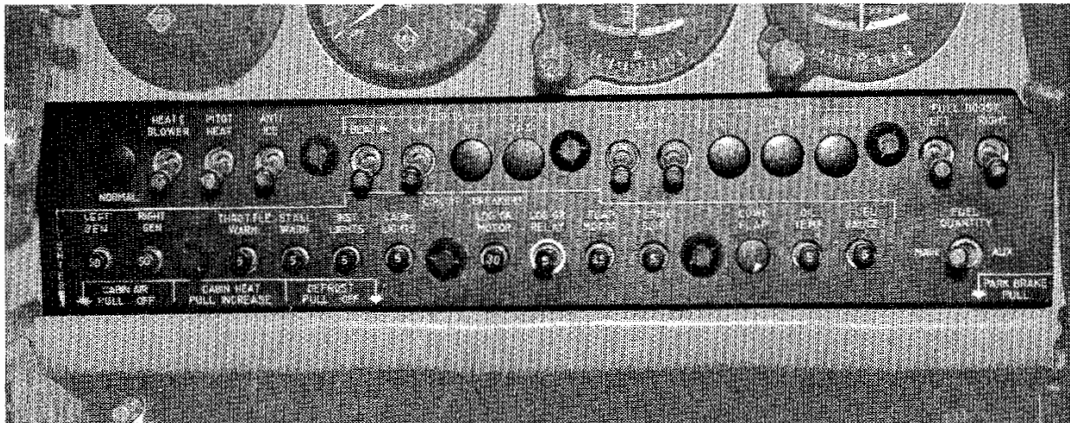

Overhead panel lights provide both cabin and instrument lighting. The cabin dome light is controlled by an "ON-OFF" switch beside the light. A rheostat switch below the control console adjusts the red overhead lights for all instruments except those just above the electrical panel. They are lighted by post lights controlled by a second rheostat switch. A third rheostat switch below the control console adjusts the lighting for the electrical panel, fuel selector panel, radio panel, and the trim tab and mechanical landing gear position indicators.

## HEATING AND VENTILATING SYSTEM

Fresh air heating and ventilation in your Travel Air provides an ample supply of heated or cold air to the cabin in flight. Manually operated controls regulate the heater and air supply to suit individual preferences. The system consists of a 50,000 BTU combustion heater, an igniter unit, two fuel pumps, a fuel filter, shut-off valve, and temperature limiting thermostats. The addition of an optional ventilation air blower equips the heater for ground operations.

In flight, ram air pressure forces fresh air through the system. For ground operation, the ventilation air blower maintains air flow through the system. The blower is controlled by a switch connected to the landing gear actuation linkage so that the blower operates with the landing gear down, the "Heat and Blower" switch "ON" and the "Cabin

Air" control in. The blower is shut off automatically when the gear is retracted, and may be shut off manually with the "Heat and Blower" switch or by pulling the "Cabin Air" control out approximately half way, which partially closes the iris valve and opens a blower switch connected to the control linkage. This switch also turns off the heater, since with the iris valve only slightly open, the intake air is insufficient for proper heater operation.

Heater operation is controlled by a ductstat mounted in the right air outlet behind the instrument panel. It acts as a cycling thermostat to maintain the temperature selected with the "Cabin Heat" control beneath the electrical panel. The ductstat's upper limit is set at 180° F to prevent uncomfortably-hot air from entering the cabin. To obtain more cabin heat during flight in low outside air temperatures, pull the "Cabin Air" control out as far as possible without shutting off the heater. This reduces the volume of incoming cold air and allows the heater to raise the temperature of the air to a comfortable level.

A normally-open thermostat in the heater discharge plenum acts as a safety device to render the heater system, except the blower, inoperative if a malfunction should occur which results in dangerously-high temperatures. This thermostat is set to close at 300°F, grounding a fuse in the heater power circuit. The fuse is located on the upper right hand segment of the bulkhead behind the instrument panel. This location was chosen deliberately for inaccessibility in flight, to make certain any malfunction causing the overheat fuse to blow is corrected before the heater is operated again.

In flight, fuel for the heater is drawn from the left main wing tank by two electric fuel pumps. When the aircraft is equipped with the ventilation air blower, only one pump operates during ground operation. This is accomplished by a switch operated by the landing gear linkage. The heater fuel line is equipped with a strainer. A spring-loaded, electrically-operated, solenoid valve closes when the heater is off, preventing seepage of fuel into the heater.

The heater ignition unit, mounted in the nose cone, uses a vibrator to provide interrupted current for its high-voltage coil. The unit is equipped with two sets of points; at each 1000-hour inspection of the airplane, the heater electrical system is modified to place an unused set of contact points in service.



In addition to the air supplied to the cabin through the heater fresh-air system, a manually retractable air scoop on top of the cabin conducts outside air to individual fresh-air outlets in the overhead upholstery panel above each seat. The outlets, which can be manually adjusted to control both the quantity and direction of air flow, allow individual selection of cool fresh air for each passenger's comfort. During flight through inclement weather or for maximum noise suppression, the air scoop may be closed by operating a push-pull control located on the overhead panel. It is easily accessible from the pilot's seat.

To further the circulation of air through the cabin, a manually controlled exhaust vent is installed in the overhead upholstery panel behind the rear seats.

## **VACUUM SYSTEM**

Suction for the vacuum-operated gyroscopic flight instruments is supplied by two engine-driven vacuum pumps, interconnected to form a single system. Either vacuum pump has sufficient capacity to maintain the complete aircraft gyro instrumentation.

The suction produced by each pump is controlled by an adjustable, spring-loaded regulator valve in the instrument line just ahead of the instrument panel. The valves are set to bleed air into the system as required to maintain the correct suction supply.

A suction gage on the instrument panel indicates the amount of suction in the vacuum system in inches of mercury. A reading within the yellow arc on the gage with both engines operating at cruise power indicates that the regulator system requires adjustment or that one vacuum pump has failed. The cause of an unsatisfactory suction reading should be determined as soon as practicable. Failure of one vacuum pump can be detected by noting suction pressure with each engine operating individually.

Air entering the system is taken in through the using instruments. To eliminate dust and grit which might damage the instruments, each instrument air intake is fitted with a filter. Sluggish or erratic operation of vacuum-driven instruments accompanied by a normal suction gage

reading indicates that clogged filters are reducing the volume of intake air to less than the instruments require.

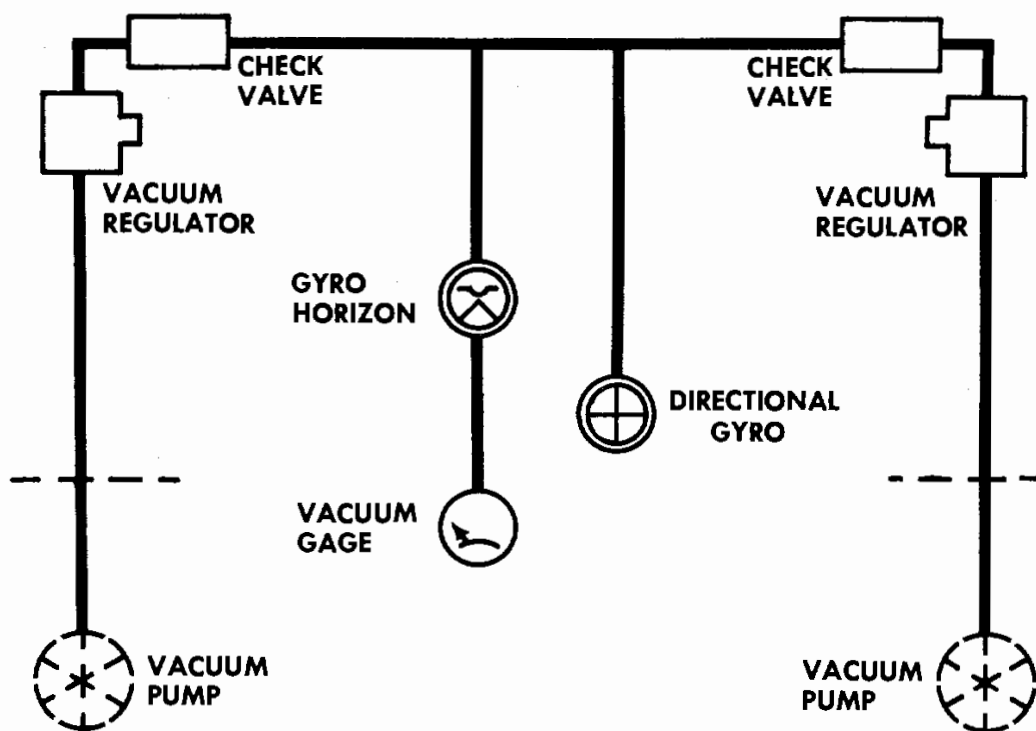

### **FOR YOUR COMFORT, CONVENIENCE AND SAFETY**

Your BEECHCRAFT, built to standards in excess of actual requirements, offers you safety, as well as comfort and convenience items, unexcelled by any airplane in its class. Other items of this nature which are offered as optional equipment and may be installed either at the factory or by your distributor, dealer or Certified Service Station, are listed in the latter portion of this section.

### **Control Tower Visibility**

With increasing congestion around airports, the ability to see about you is vital to safe take-offs and landings. All occupants of the aircraft have excellent visibility through the large, ultraviolet-proof windshield and tinted side windows. The large panoramic rear windows afford maximum flight enjoyment for passengers and provide excellent rearward visibility for the pilot.

## **Landing Gear and Flap Indicators**

The position of the landing gear and the wing flaps is indicated by signal lights on the instrument panel. Also, the flaps are visible through the windows and an illuminated mechanical pointer below the instrument panel indicates the position of the nose gear. To avoid accidental tripping of the landing gear and flap switches, each is designed to be pulled out of a detent before it can be repositioned.

## **Landing Lights**

A sealed-beam landing light mounted in the nose cone and an optional light installed on the nose landing gear are scientifically mounted to produce maximum effectiveness for night landings. The lights are operated independently by separate switches on the electrical panel; prolonged operation during ground maneuvering should be avoided. Conventional position lights on the wing tips and tail cone are operated through a flasher unit designed to give steady lights if a malfunction occurs, and are controlled by a toggle switch on the electrical panel. The flasher unit is omitted when the airplane is equipped with either the single or dual optional rotating beacon installation.

## **Stall Warning Indicator**

As an impending stall is approached, a stall warning indicator sounds a warning horn on the left side of the cabin forward bulkhead while there is still ample time for the pilot to correct his attitude. The stall warning indicator, triggered by a sensing vane on the leading edge of the left wing, is equally effective in all flight attitudes and at all weights and airspeeds. Irregular and intermittent at first, the warning signal will become steady as the aircraft approaches a complete stall.

## **Safety Belts**

The Beech designed high-strength safety belts on your Travel Air, if properly worn, will keep occupants snugly in their seats in rough air or under rapid deceleration. The safety belts are mechanically simple and comfortable, and wearing them, you have sufficient freedom of movement to easily operate all the controls. The nylon strap material, in colors complementing the upholstery, is soil resistant and easily cleaned. The airline-type harness buckles may be fastened or released quickly and are easily adjusted.

## **Instrument Panel Glare Shield**

The attractive instrument panel glare shield, made of foam rubber encased in dull-finish vinyl, is shaped to cover the contour above and between the instrument panel and the windshield. This shield, extending aft over the instrument panel in an eyebrow effect, gives added protection for the instruments and windshield against reflected light in both day and night flying.

## **Cabin Interior**

Your BEEHCRAFT offers truly "hushed" air travel through its acoustically engineered and soundproofed cabin. Pilot and passenger fatigue factors have been taken into consideration wherever they are pertinent in designing the airplane. These primary design considerations assure relaxed, comfortable, speedy travel. The travel-designed interiors include cabin loudspeakers, attractive upholstery, and wall-to-wall carpet.

Ample baggage area is provided in the nose compartment and behind the rear seats. A spacious accessory shelf above the aft baggage area provides a readily accessible, out-of-the-way space for miscellaneous articles that may be needed during flight. A large door on the right side of the fuselage facilitates loading and unloading while on the ground. The compartment door has a key type lock for security of items in the baggage compartment when the aircraft is unattended.

The Travel Air's seats may be adjusted to fit the individual comfort requirements of their occupants. All standard seats are adjustable fore and aft, the front seats by pulling up on the lever to the right of the cushion, and the rear seats by pulling up on the crossbar handle below the front of the cushion. Standard seat backs, except that of the pilot's seat, are adjustable from the vertical to the fully reclined position. Out-board armrests for the front and rear seats are built into the cabin side-walls. A large armrest between the front seats (installed as optional equipment) may be raised or placed flush with the seat cushions. Rear seat center armrests fold into a stowed position behind the seat backs. The optional fifth seat features individual removable armrests.

Except when the aircraft is to be operated from the right side, the right hand set of rudder pedals (optional) may be laid forward against the floorboards, for maximum leg room.

*Comfort . . . . . Convenience . . . . .*

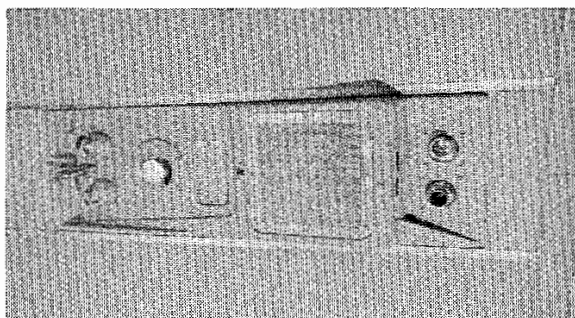
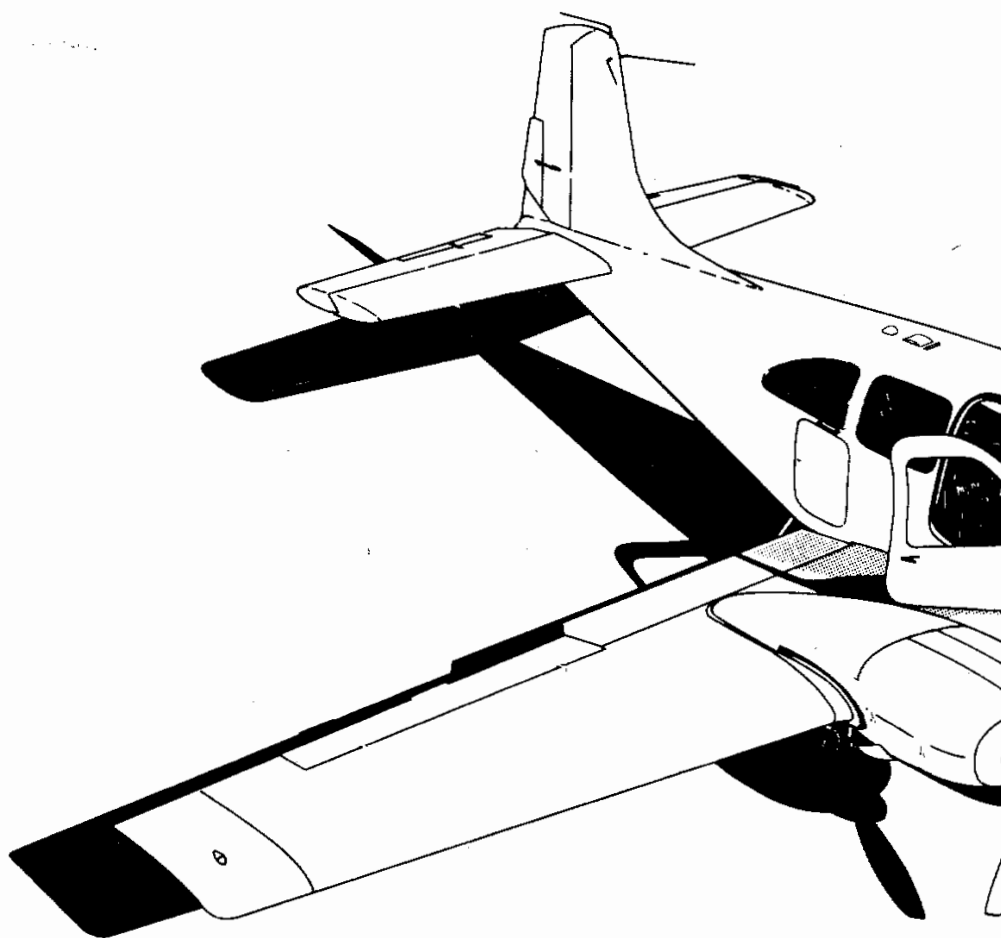

**FRESH  
AIR  
SYSTEM**

# Safety . . . . .

**UNITIZED  
IGNITION  
PANEL**

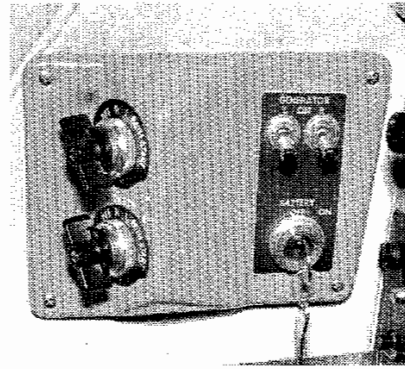

**CONTROL TOWER  
VISIBILITY**

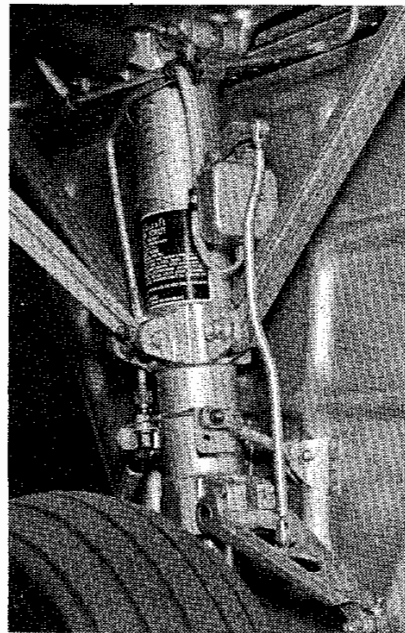
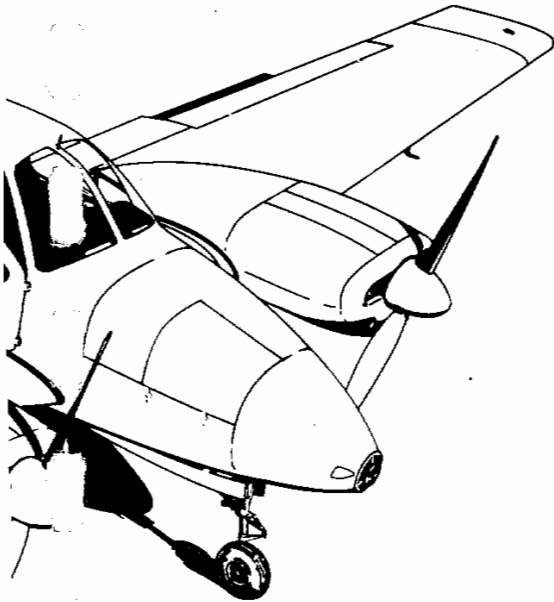

**LANDING GEAR  
SAFETY SWITCH**

**INTERIOR  
APPOINTMENTS**

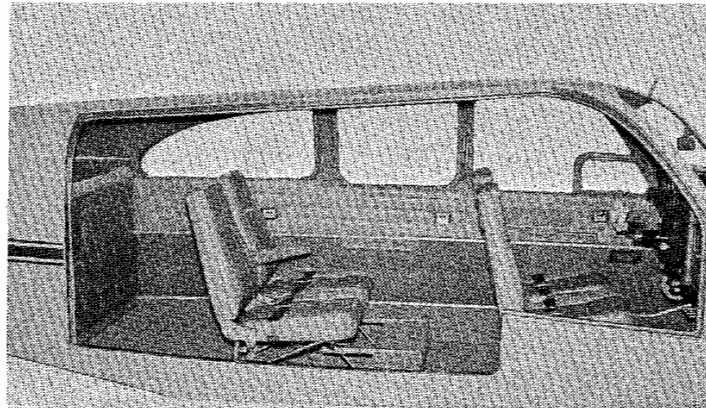

# *Optional Equipment . . .*

**To Meet Your Flying Requirements for . . .**

## **FLIGHT EQUIPMENT**

**DUAL CONTROL WHEEL.** Indispensable for instruction and transition purposes.

**AUTOPILOT SYSTEM.** A selection of autopilots makes "hands-off" flying a reality. These fully automatic systems are easy to maintain and are almost "fool-proof" in operation . . . they let you sit back and relax . . . greatly increase flight enjoyment on every cross-country flight. Altitude hold can be included to keep you at your assigned altitudes on IFR flights and to maintain separation altitudes on VFR flights for added safety and peace of mind.

**DUAL TACHOMETER.** Enables you to monitor the rpm of both engines in a single glance and saves valuable instrument panel space for additional equipment.

**FLIGHT AND ENGINE HOUR RECORDERS.** Automatically record flight and engine operating hours expended by your airplane.

**RADIO EQUIPMENT.** A wide selection of communication and navigation equipment permits you to install the radio package that exactly fits your needs.

## **SAFETY EQUIPMENT**

**INSTRUMENT POST LIGHTS.** Make night flying easier and safer with evenly distributed illumination, without glare or reflections, of all the panel instruments.

**SINGLE OR DUAL ROTATING BEACONS.** A continuous-rotating, high-intensity warning light flashes your in-flight position to other aircraft. The added safety provided by these items makes them good insurance.

**SURFACE DEICING SYSTEM.** This lightweight deicing system is capable of removing most ice accumulations that threaten cold weather operations. When used in conjunction with the propeller anti-icer and windshield defroster, it gives you airline weather capability.

**PROPELLER ANTI-ICER.** A must for "all-weather" flying. Allows maximum power even under severe icing conditions.

**WING ICE LIGHTS.** A flick of the switch and you have visual confirmation whenever ice is present on your wings. You'll value this important safety item and the added confidence it gives you.

**PROPELLER UNFEATHERING ACCUMULATOR.** Gives quicker, more positive propeller unfeathering without the use of the engine starter.

**STATIC WICKS.** Drain static electricity from the airplane to provide better radio reception.

**OXYGEN SYSTEM.** Allows high-altitude flights for greater speeds, and provides increased safety and comfort at intermediate altitudes.

..... **FOR YOUR**

**Beechcraft**

..... **Safety . . . Comfort . . . Pleasure**  
**Convenience . . . Efficiency**

## **EQUIPMENT FOR COMFORT — PLEASURE — AND CONVENIENCE**

**SUPER SOUNDPROOFING.** Thick blankets of modern fiberglass insulation and quarter-inch windshield, seal noise and vibration outside.

**FIFTH SEAT ARRANGEMENT.** The 5-seat arrangement incorporates a removable, forward-facing seat in the rear of the cabin.

**FRONT AND REAR SEAT HEADRESTS.** These pillowed headrests make each flight a more comfortable and enjoyable experience. Weight of installation is one pound each . . . interchangeable among all four standard seats.

**FRONT AISLE ARMREST.** Provides armchair comfort for front seat occupants without sacrificing space used for getting in and out. When not in use, the armrest can be positioned flush with the seat cushions.

**EXECUTIVE WRITING DESK.** A combination writing desk and magazine rack of attractively finished wood can be installed on the back of any standard seat. The writing table can be folded and placed in the rack until required.

**VENTILATION AIR BLOWER.** Allows airflow through the heating and ventilation system during ground operation and in flight whenever the landing gear is down.

**EXTERNAL POWER RECEPTACLE.** Permits starting the engines with external power, eliminating unnecessary battery loads, particularly in cold weather.

## **MISCELLANEOUS OPTIONAL EQUIPMENT**

**DUAL RUDDER PEDALS AND HYDRAULIC BRAKES.** A must for instruction and transition purposes.

**OPTIONAL WING FUEL CELLS.** Two 25-gallon main cells and two 31-gallon auxiliary cells replace the standard 40-gallon leading edge cells. This configuration provides an additional 32 gallons of usable fuel for long-range flights.

**NOSE GEAR LANDING LIGHT.** The addition of a second landing light on the nose gear is of particular value for night operation.

**ELECTRIC COWL FLAPS.** Enjoy the convenience of rapid, smooth cowl flap operation at the flick of a switch.

**24-AMPERE-HOUR BATTERIES.** Two 24-ampere-hour, 12-volt batteries connected in series replace the standard 17-ampere-hour, 24-volt battery for added starting power, an important factor in cold weather flying.

**40-AMPERE GENERATORS.** Two 40-ampere, 24-volt generators replace the standard 25-ampere generators to supply extra current for the operation of optional electrical equipment.



## **SECTION II**

# ***Operating Check Lists***

This section has been prepared to give you a quick and easily accessible reference to all operational check lists needed for the normal flight of your Travel Air. The general techniques presented are based on the recommendations and data compiled by Beech Aircraft Corporation pilots who have test flown and demonstrated the aircraft. The procedures given are intended merely to assist you in developing a good flying technique for your airplane. They constitute the manner in which a good pilot would perform each item under average conditions.

As you become familiar with your airplane, and the individual circumstance under which you fly it, you may find that variations in these techniques will better suit your requirements or personal preference. These checks, if well organized and studied, should become so much a matter of habit that you will find it unnecessary to make reference to this portion of the manual except as a refresher. Made carefully, these checks not only will help prevent mishap or malfunction during operation, but will help lower maintenance cost.

Whether the check is a visual exterior check or a specific operational check, it is a definite responsibility the pilot owes to himself and to his passengers. However, as stated previously, the procedures are intended primarily as guides and are no substitute for good judgment.

Know your airplane's capabilities as well as your own.

## WALK AROUND INSPECTION

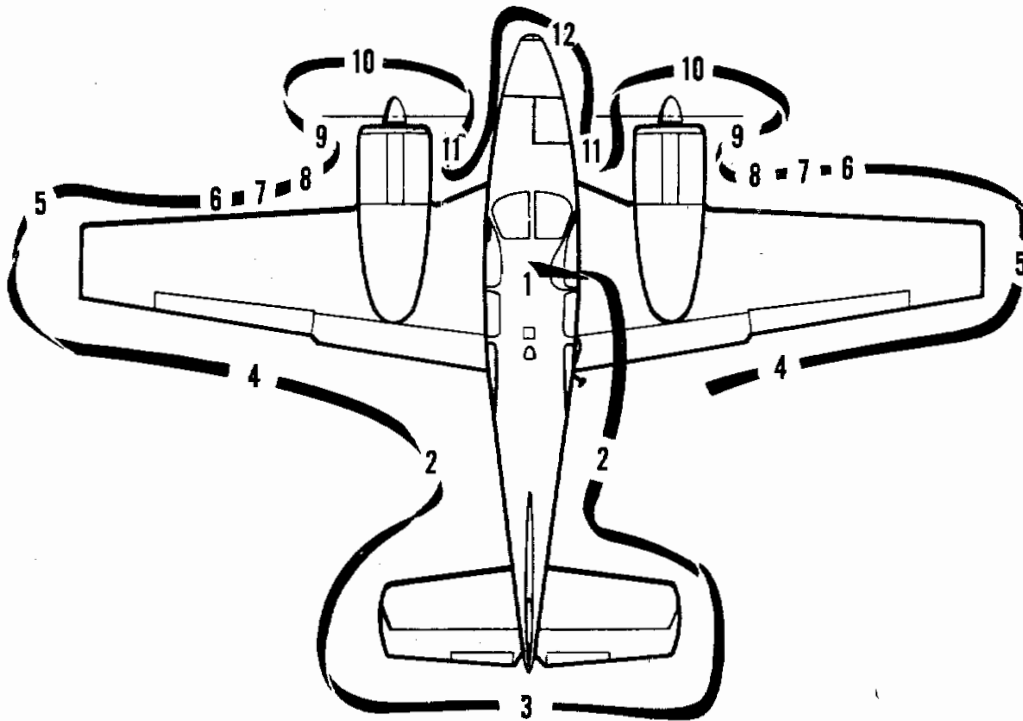

### PREFLIGHT INSPECTION

1. Cockpit — checked; battery and ignition switches "OFF." Tab controls "O"; remove and stow control lock.
2. Static pressure buttons free of foreign material.
3. Check empennage and control surfaces. Aft baggage compartment — cargo secure.
4. Inspect wings, ailerons and flaps.
5. Wing tips — checked; remove pitot cover and tie-down lines.
6. Outboard fuel tanks — FULL, fuel tank caps — secured.
7. Drain fuel strainers in wheel wells, fuel system low spots at bottom of fuselage, and fuel cell sumps.
8. Tires and shock struts inflated and clean. Landing gear safety switch — checked.
9. Check each nacelle for oil, fuel or exhaust leakage.
10. Propeller blades — checked; induction filter clean.
11. Check engine oil level; inboard fuel tanks — FULL; secure filler caps, fasten cowling.
12. Forward baggage compartment — cargo secured; weight and balance — checked; all inspection doors — secured.

## BEFORE STARTING CHECK

1. Set parking brake.
2. Battery, and generator or alternator switches — ON (battery, and generator or alternator switches — OFF, if external power is used).

### CAUTION

On aircraft equipped with alternators, the alternator control switches must be turned OFF prior to connecting an auxiliary power unit for starting, battery charging, or electrical equipment check-out. This procedure protects the voltage regulators and system electrical equipment from electrical power fluctuations (voltage transients). Also, during cold weather

starts, the alternator control switch should be turned OFF to minimize battery power drain.

3. Check circuit breakers, all switches and controls.
4. Landing gear switch DOWN. Mechanical indicator full DOWN.
5. Cowl flaps — OPEN.
6. Fuel selector valves — on MAIN or AUX.
7. Alternate air controls — IN — normal.
8. Check the fuel level indication for all cells.
9. Check the landing gear and flap position lights.

## NORMAL STARTING PROCEDURE (If in doubt, use flooded engine procedure.)

1. Position throttles  $\frac{1}{4}$  open.
2. Propeller controls — High rpm.
3. Mixture controls — full rich.
4. Auxiliary fuel pump — ON; when fuel flow is indicated, turn auxiliary fuel pump off and engage starter.
5. Warm-up 800 to 1300 rpm.
6. All gages — normal readings.
7. Using the same procedure, start the remaining engine and allow to warm-up.
8. Disconnect external power, if used, and turn battery and generator or alternator switches ON.

## HOT OR FLOODED ENGINE STARTING PROCEDURE

1. Position throttles  $\frac{1}{4}$  open.
2. Propeller controls — High rpm.
3. Mixture controls — Idle Cut-Off.
4. Engage starter and allow engine to clear excess fuel. As soon as engine starts, move mixture control to full rich. If engine fails to run, use auxili-

## HOT OR FLOODED ENGINE STARTING PROCEDURE (Cont'd)

- |   |  |
|---|--|
| ary fuel pump as necessary.                                 | allow to warm-up.  |
| 5. Warm-up 800 to 1300 rpm.                                 | 8. Disconnect external power, if used, and turn battery and generator or alternator switches ON. |
| 6. All gages — normal readings.                             |  |
| 7. Using the same procedure, start the remaining engine and |  |

## BEFORE TAKE-OFF CHECK

- |   |   |
|---|---|
| 1. Exercise propellers at 2200 rpm. Set in high rpm.  | 7. Mixtures — FULL RICH (adjust to take-off power for field elevations above 3000 feet, mean sea level. |
| 2. Fuel flow check — purge system of vapor by drawing fuel from all tanks. Turn to MAIN for pre-take-off checks and for take-off. | 8. Trim — set for take-off, depending on load.  |
| 3. Check magnetos at 2000 rpm (maximum drop, 125 rpm).  | 9. Alternate air controls — IN.   |
| 4. Propellers — reduce to 1500 rpm and check feathering action. Maximum rpm drop 500 rpm.   | 10. All instruments and controls — checked. Altimeter and gyro set.                                     |
| 5. Check all controls for full travel and freedom of movement.  | 11. Flaps — as required (20° for short field take-off).   |
| 6. Auxiliary fuel pumps — as conditions require.  | 12. All doors and windows — LOCKED.   |
|   | 13. All safety belts — FASTENED.  |
|   | 14. Parking brake — OFF.  |

## BEFORE LANDING CHECK

- |  |  |
|--|--|
| 1. Safety belts — secure.  | 5. Auxiliary fuel pumps — as conditions require. |
| 2. Check main cell fuel quantity, then switch both fuel selector valves to main cells. | 6. Flaps — as required.                          |
| 3. Mixtures — FULL RICH.   | 7. Cowl flaps — closed until on the ground.      |
| 4. Landing gear DOWN; check indicators.  | 8. Propellers — High rpm.                        |

## SHUTDOWN

- |  |   |
|--|---|
| 1. Parking brake — set.                  | 4. Auxiliary fuel pumps — OFF.                    |
| 2. Electrical and radio equipment — OFF. | 5. Throttles — advance to approximately 1100 rpm. |
| 3. Propellers — High rpm.                | 6. Mixtures — IDLE CUT-OFF.                       |

## SHUTDOWN (Cont'd)

7. Ignition switches — OFF — after engine stops firing.
8. Battery, and generator or alternator switches — OFF.
9. All switches — OFF.
10. Fuel selector valves — OFF, if airplane is to remain parked for any length of time.
11. Controls — locked, if conditions warrant.

## **SECTION III**

# ***Performance Specifications and Limitations***

In this section, for your convenient reference, charts and tabular listings of speeds, performance and engine limitations have been grouped. The limitations and performance data in this section has been established by flight tests and engineering calculations to assist you in operating your Travel Air. The limitations have been approved by FAA and are mandatory. These charts and listings have been established under normal operating conditions, the flight tests being made under standard atmospheric conditions with a maximum gross weight; therefore, allowances for actual conditions must be made. Advance planning, allowing for any changes which may occur in operating conditions due to weather, temperature, altitude or loading, will assure you of safe, fast, comfortable and economical transportation.

S  
E  
C  
T  
I  
O  
N  
II

During all phases of engine and flight operation, observe the rpm and manifold pressure limits as computed on your horsepower calculator to avoid excessive cylinder pressures. Use your horsepower calculator to arrive at rpm, manifold pressure and fuel flow settings for climb and cruising flight. Note that the manifold pressure required to obtain a given horsepower will vary with outside air temperature. When increasing power, set rpm first, then manifold pressure. Make power reductions with manifold pressure first, then rpm.

Become familiar with your Travel Air and its operation. Know the contents of this handbook.

### **NOTE**

The airspeed computations presented in this section are based on *Indicated Airspeed*, except Airspeed Limitations, which are *Calibrated Airspeeds*. Corresponding performance figures appearing in the FAA Approved Airplane Flight Manual and installed as placards in the airplane are *Calibrated Airspeeds*.

# *Airspeed Charts*

## **TAKE-OFF SPEEDS (IAS)**

### **Normal**

Take-off .....	85 mph/ 74.0 kts
Climb-out at 50 feet .....	100 mph/ 87.0 kts

### **Short Field**

Take-off .....	70 mph/ 61.0 kts
Climb-out .....	90 mph/ 78.0 kts

## **CLIMB SPEEDS (IAS)**

### **Two Engine**

Cruising climb speed (25 in. Hg at 2450 rpm, gear and flaps up) .....	140 mph/121.5 kts
---	-------------------

Best rate of climb speed, 5,000 ft. (gear and flaps up) .....	103 mph/ 89.5 kts
(gear down) .....	83 mph/ 72.0 kts
(gear and flaps down) .....	79 mph/ 68.5 kts

Best angle of climb speed, 5,000 ft. (gear and flaps up) .....	83 mph/ 72.0 kts
(gear down) .....	69 mph/ 60.0 kts
(gear and flaps down) .....	69 mph/ 60.0 kts

### **Single Engine**

Best rate-of-climb speed, sea level (gear and flaps up) .....	108 mph/ 94.0 kts
--	-------------------

Best angle-of-climb speed, sea level (gear and flaps up) .....	98 mph/ 85.0 kts
Minimum control speed .....	80 mph/ 69.5 kts





# ***Engine Operation***

## ***Limitations***

### **Maximum Power**

(all operations) .....180 hp @ 2700 rpm

## **ENGINE INSTRUMENT MARKINGS**

### **Oil Temperature**

Caution (Yellow Arc) .....60° to 140°F  
Normal (Green Arc) ..... 140° to 245°F  
Maximum (Red Radial) .....245°F

### **Oil Pressure**

Minimum Pressure (Red Radial) ..... 25 psi  
Normal Operating Range (Green Arc) .. 65 to 85 psi  
Maximum Pressure (Red Radial) ..... 85 psi

### **Manifold Pressure**

Normal Operating Range (Green Arc) .. 14.5 to 29.0" Hg  
Maximum, Sea Level (Red Radial) ..... 29.0" Hg

### **Cylinder Head Temperature**

Normal Operating Range (Green Arc) .. 200° to 500°F  
Maximum Temperature (Red Radial) ... 500°F

### **Tachometer**

Engine Warm-Up ..... 1300 rpm  
Normal Operation (Green Arc) ..... 2000 to 2700 rpm  
Maximum (Red Radial) ..... 2700 rpm

### **Fuel Flow**

Normal (Green Arc) ..... 0 to 17.0 gph  
Maximum (Red Radial) ..... 10.0 psi

## Suction

Minimum (Red Radial) . . . . .	3.75" Hg
Check Pumps (Yellow Arc) . . . . .	3.75" to 4.8" Hg
Normal (Green Arc) . . . . .	4.8" to 5.25" Hg
Maximum (Red Radial) . . . . .	5.25" Hg

## Gliding Distance Table

The Gliding Distance Table shown below gives the horizontal distance you can glide, assuming the glide ratios shown, for several different altitudes and wind conditions. Maximum glide is obtained with propellers feathered, gear up, and flaps up. Refer to Section V for correct glide ratio procedure.

### GLIDE DISTANCE (Statute Miles)

IAS	111	113	116	120	123	126	130
Altitude Above Ground (Feet)	30 MPH Tail-wind	20 MPH Tail-wind	10 MPH Tail-wind	Zero Wind	10 MPH Head-wind	20 MPH Head-wind	30 MPH Head-wind
1000	3.3	3.0	2.8	2.6	2.4	2.2	2.0
2000	6.6	6.1	5.6	5.2	4.7	4.3	3.9
3000	9.8	9.1	8.4	7.7	7.1	6.5	5.9
4000	13.1	12.1	11.2	10.3	9.5	8.6	7.8
5000	16.4	15.2	14.0	12.9	11.8	10.8	9.8
6000	19.7	18.2	16.8	15.5	14.2	13.0	11.7
7000	22.9	21.2	19.6	18.0	16.6	15.1	13.7
8000	26.2	24.2	22.4	20.6	18.9	17.3	15.6
GLIDE RATIO	17.3	16.0	14.8	13.6	12.5	11.4	10.3

## OPTIONAL DEICING SYSTEM DURATION

RESERVOIR PRESSURE (psig)	DEICING CYCLES AVAILABLE	ENDURANCE AT 1 CYCLE PER 3 MINUTES
100	4	12 Min.
500 (Recharge Reservoir)	22	1 Hr. 6 Min.
1000	44	2 Hrs. 12 Min.
1500	66	3 Hrs. 18 Min.
2000	89	4 Hrs. 27 Min.
2500	112	5 Hrs. 3 Min.
3000 (Maximum Pressure)	134	6 Hrs. 42 Min.

## OPTIONAL OXYGEN SYSTEM DURATION IN HOURS (ZEP AERO)

Altitude Feet	Number of Persons Being Supplied				
	1	2	3	4	5
	(38.4 Cubic Foot Cylinder)				
10,000	7.1	4.0	2.8	2.1	1.7
15,000	6.6	3.7	2.6	2.0	1.6
20,000	6.0	3.4	2.4	1.9	1.5

Based on 95 per cent rated volume with a .018 inch metering orifice for the pilot and .016 inch metering orifices for the passengers.

## MANEUVERS

This is a normal category airplane. Maneuvers, including spins, are prohibited.

## WEIGHT AND BALANCE

It is the responsibility of the airplane owner and pilot to insure that the airplane is properly loaded. At the time of delivery of an airplane, BEECH AIRCRAFT CORPORATION provides with the airplane an FAA Approved Airplane Flight Manual which is required by the FAA to remain in the airplane at all times. In Section IV of the FAA Approved Airplane Flight Manual is compiled all of the necessary weight and balance data the owner or pilot may need in order to arrive at the necessary weight and balance computation which will assure proper loading.

## **SECTION IV**

# ***Flying Your Beechcraft***

Specific information, necessary precautions and procedures presented in this section have been determined through engineering computations and flight testing of the aircraft. The general handling technique presented is based on recommendations and data compiled by Beech Aircraft Corporation pilots who have test flown and demonstrated the aircraft and may be followed with confidence in forming your own procedures. The tables and diagrams in Section VI give a working basis for figuring the aircraft's performance under many combinations of the variable factors connected with flying. However, except for the limitations and precautions mentioned, both the procedures and the graphs are intended primarily as guides and are no substitute for good judgment.

For your convenient reference purposes, various types of data are grouped in other sections of the handbook. Section II is a complete listing of abbreviated check lists. Section III consists of tabular listings or charts of performance data, such as airspeeds, engine operation data, maneuvers, and weight and balance information. Section V covers unusual operating conditions. Section VI contains all the graphs and performance data needed for computing flight plans and other variables needed in everyday flying.

### **EXTERIOR INSPECTION**

To a pilot the general airworthiness of his aircraft is both a legal obligation and a direct responsibility to his passengers and himself. Personal attention to the preflight procedures is the mark of a safe pilot and will repay you not only in safety, but in lower maintenance costs as well.

In addition to the check lists in Section II the "Walk-around" portion of your preflight inspection should include checking the rig and free-

dom of control surfaces, visually checking the condition of the windshield, side windows, and antenna rigging, and inspecting for dents and scratches in the skin or other minor damage which should be noted and evaluated.

### **CAUTION**

Under circumstances where propeller blasts or wind conditions are likely to be encountered, when opening the cabin door, retain the door forcibly by hand and position it against the open stop, thus preventing the possibility of damage to the door or its hinges.

### **STARTING**

Look over the area around the aircraft and be sure of sufficient taxi clearance with respect to other aircraft, buildings, or other structures. Make sure the propeller blast is in the clear before running up the engines. When possible, avoid operating the engines on graveled or sandy surfaces, since the propeller blades can pick up loose pieces of rock and debris causing blade nicks and scratches.

Refer to starting check list in Section II. Each cranking period should be limited to ten or twelve seconds of operation. A five-minute cooling interval between cranking periods will extend starter life.

After the engine is started, check for oil pressure indication. If no pressure is shown in the first 30 seconds of operation, stop the engine and investigate. After oil pressure reaches normal, 65 to 85 psi, adjust engine speed to recommended warm-up rpm, then start the remaining engine using the same procedure.

### **NOTE**

Should the engine stop firing completely, due to a flooded condition, move the mixture control full aft (idle cut-off) and position the throttle control one-fourth open. Engage the starter and turn the engine through approximately ten revolutions. Following the check list procedures, attempt a restart.

## **TAXIING**

### **NEVER TAXI WITH A FLAT SHOCK STRUT**

To taxi, simply release the parking brake control and allow the aircraft to start rolling forward. Check the brakes by applying them several times lightly, thus assuring that the brakes are functioning properly. Govern your taxi speed with throttle coordination. Most turns may be made with the steerable nose wheel and the throttles. Tight turns may be accomplished by applying a combination of inside brake and outside power. When taxiing over rough surfaces, use minimum power settings and allow the aircraft to coast over obstructions. Hold the control column full back to reduce weight and relieve loads on the nose gear assembly.

## **ENGINE WARM-UP**

Head the aircraft into the wind. Straighten the nose wheel and set the parking brake. Allow the engines to complete their warm-up at the rpm prescribed in Section III. Limit ground running to a minimum to avoid engine overheating. To attain maximum engine cooling, place propellers in full low pitch (high rpm). After completing the instrument check pull the propeller control lever aft to the high pitch detent (at 2,200 rpm) and reposition it full forward again after the propeller has changed to high pitch (low rpm) and the engine speed has stabilized. Exercise propeller through this cycle two or three times to assure correct governing action.

### **NOTE**

When exercising propellers in their governing range, do not move the control lever aft past the detent. To do so will allow the propeller to change rapidly to the full feathered position, imposing high stresses in the propeller blade shank and engine.

Perform the following magneto checks, and propeller feathering check:

1. With ignition switch in the "BOTH" position, advance the throttle to approximately 2000 rpm.
2. Place ignition switch in the "R" position and note the rpm reading, then return switch to "BOTH." Maximum drop, 125 rpm.
3. Place ignition switch in the "L" position and note the rpm reading, then return switch to "BOTH." Maximum drop, 125 rpm.
4. Reduce engine speed to 1500 rpm and check feathering action. Do not allow rpm to drop more than 500 rpm.

5. Reduce the engine to idle rpm and place the ignition switch in the "OFF" position just long enough to determine if the engine has stopped firing.
  6. Check the magnetos of the opposite engine in the same manner.
- To avoid spark plug fouling, do not idle the engine at low speed for long periods.

#### **CAUTION**

Do not place ignition switch in "START" position when engine is running.

With the propeller controls full forward, in the low pitch (high rpm) position, open both throttles simultaneously with a steady smooth motion and observe if power is developed equally in both engines. Return the throttle to warm-up rpm range. Bear in mind that atmospheric conditions affect both the manifold pressure and rpm obtainable and that on a cold day with high barometric pressure, it is possible to exceed the manifold pressure limit.

#### **NOTE**

The propeller feathering or twisting force which moves the blades toward the high pitch (low rpm) position is maintained at a constant pressure by blade counterweights and a propeller feathering spring. This force is maintained in a pressure-balance condition against boosted engine oil pressure which in turn is regulated by the propeller control lever, thus, the controllable or variable pitch feature of the propeller. Since feathering will occur whenever this boosted oil pressure is relieved it is not necessary to check the propeller feathering cycle during *each* engine run-up.

#### **NORMAL TAKE-OFF**

When you are ready for the take-off run and have moved into position on the active runway, release the brakes and open both throttles smoothly and evenly to take-off power, maintaining positive directional control with the rudder pedals.

#### **CAUTION**

If you are taking off or landing behind a large multi-engine or jet aircraft, allow sufficient spacing so that the air turbulence in the wake of the other airplane will dissipate and settle before you encounter it.

As lift-off speed is *approached*, apply a steady back pressure, sufficient to bring the wings to a slightly positive angle of attack. As lift-off speed is *reached*, the aircraft should become airborne. Let the airplane accelerate to a safe single-engine climb speed (see Single-Engine Climb Performance graphs, Page 6-8), retract the landing gear, and start climbing.

On a hot day a longer run will be required for take-off than under average temperatures. The same rule is true as field elevation increases, since lift is obtained only through actual density of air or atmosphere. Though airspeed indications will be the same, almost twice the runway length will be required to attain lift-off speed at an airport elevation of 6,000 feet than under the same conditions at sea level. Watch the airspeed needle rather than the runway markers and be sure to have *sufficient airspeed* before applying back pressure for the lift-off. Other conditions to be considered are runway surface condition, runway gradient, aircraft gross weight, and surface winds. A good take-off speed depends on the correct allowances for all these factors. Do not forget them.

As specifically pointed out in the "Before Take-Off" check list, it is the pilot's responsibility to determine that all doors and windows are locked before he commences his take-off run. If the cabin door is not locked, it is possible for it to come unlatched in flight. Should the door come open, the rushing air will cause a high noise level. Since it occurs suddenly, the sound of the wind may be startling to those in the cabin; however, there is no reason for undue alarm as the flight characteristics of the aircraft are not affected by an open door.

Usually an unlocked door will open during or just after take-off. If this happens the pilot or passengers should not become alarmed; just forget the door and return to the field in a normal manner. The door will trail in a position 3 to 4 inches open and will not buffet.

## **CLIMB**

A climb at best rate-of-climb speed will get you to altitude quickly. It may be mandatory in IFR conditions, or save some fuel overall if you have a good tail wind aloft. However, you will have reduced



forward visibility due to the high climb angle and the ascent will be less comfortable for your passengers. On the other hand, a cruising climb will give you good visibility, it will be more comfortable, and with good fuel management it may save both time and fuel, since you can make shallow climbs at near cruise speed with only moderate power increases. Your choice of method will depend on the weather, the length of the flight, your load, and your own preference. 2,450 rpm and 25 in. Hg is suggested as a cruise climb power setting.

For the best rate of climb, which will give the greatest gain in altitude per minute, use maximum continuous power. Hold the best rate-of-climb speed shown on the climb graph for your altitude.

To obtain best engine power the mixture may be leaned at any altitude, providing cylinder head temperatures are monitored. Full throttle operations should be avoided below 5,000 feet with an engine speed of less than 2,450 rpm.

### **CAUTION**

If dense haze or clouds are encountered the rotating anti-collision beacon should be turned off. The reflection of these lights can produce severe vertigo.

### **CRUISE**

Level off when you have reached your intended cruising altitude and maintain climb power until you have accelerated to your intended cruising IAS. This procedure will allow your airspeed, engine temperatures, and power settings to stabilize in a shorter period of time.

As cruising speed approaches, reduce your power settings. There is no "best cruise power setting for all flights." Your choice of power settings will depend on load, temperature, altitude and perhaps most important, the purpose of your flight. You should, however, weigh these factors in advance and decide on your approximate power settings during your flight planning prior to take-off. The graphs in Section VI were placed there to aid you in doing so.

Since efficiency of the aircraft in cruise is affected considerably by its trim, your trimming procedure becomes an important task. Using the

turn-and-bank indicator, adjust the rudder trim as required to zero the ball, then adjust the elevator and aileron trim. By stabilizing your directional control first you eliminate any slipping or skidding and the excess drag that results. For maximum efficiency merely trimming "hands-off" is not sufficient. Use turn-and-bank, rate-of-climb, airspeed and gyro instruments as trimming aids. They supply a far more reliable reading of what the aircraft is actually doing than may otherwise be detected.

Synchronize the propellers and make final mixture adjustments using the following recommended leaning procedure:

1. Set manifold pressure and rpm for cruise power selected. Reset mixture control for best power setting. (This is the high end of the fuel flow range shown on the gage for the power being used.)
2. After engine temperatures are stabilized at cruise condition (usually 5 to 15 minutes of operation), the mixture control may be reset for an economy mixture. (This is the lower portion of the fuel flow range specified for the power being used.)
3. When an economy setting (Step 2) is in use and a change in power setting is to be made, it is recommended that the mixture control be returned by gage to approximately best power setting before changing the throttle or propeller setting.

The fuel selector valves may be positioned to use fuel as desired while normal cruising operations are continued. However, since your take-offs, climbs and landings must be made using the main fuel cells only, a sufficient reserve for a safe landing at your destination must be maintained. Providing the length of a flight will allow enough fuel for this reserve, the main cells only may be used for this operation. Otherwise, you should switch to the auxiliary fuel cells when you have established your cruising altitude. Also remember that the auxiliary fuel and crossfeed systems may be used in level flight only. When one selector valve is positioned on crossfeed, both engines are using fuel from a cell indicated by the remaining selector valve. Normal operation allows fuel to be consumed from the cell as indicated by the fuel selector valves.

Normal cruise control should be used for all flying when weather and distance are well within the normal operating limitations of the

aircraft and its pilot. The power settings used, however, will be governed basically by the objective of the flight — high speed, economy, or comfort. In general, your climb operation should not exceed 90% power. Level flight cruise operations should be at the lowest power that will satisfy the speed requirements. Observing these limits will normally result in the optimum balance between aircraft performance and over-all operation economy.

Cruise control for maximum range differs from that for maximum endurance chiefly in the airspeeds used. Range increases with increased airspeed due to the improvement in aerodynamic efficiency until the speed reaches a point where the increased drag and the proportionally higher fuel requirements of the engines begin to offset the aerodynamic improvement. Conversely, a speed below this point also will result in fewer miles per gallon and longer flight time, due to increased drag from the less efficient flight attitude of the aircraft and a decrease in both engine and propeller performance.

This point of maximum range, in terms of optimum airspeed, must be correctly selected for a given altitude, and must be closely maintained if maximum aircraft performance is to be realized. The selection of this airspeed is complicated by several variables: altitude, wind conditions at that altitude, and propeller and engine efficiency. As shown on the range at altitude graphs, the airspeed necessary for maximum range may be as much as 20% less than maximum cruise airspeed. In selecting the power settings you should use and in predicting your performance, you must also consider weather and terrain, since they will greatly influence your altitude choice.

Maximum endurance cruise control is a flight technique which will keep the airplane in flight the longest time with the fuel available. To obtain minimum fuel consumption, the power is reduced to the lowest value at which the aircraft will fly and handle satisfactorily. In practice, this method of operation is used only in emergencies occasioned by weather, traffic, or other conditions. This is efficient operation only in terms of fuel consumption per hour. With reduced power the angle of attack of the wing must be increased to maintain lift. This, in turn, produces increased drag and low flight speeds. In terms of miles per gallon, the flight operation is inefficient; it should be used only when you are going nowhere — for example, in a hold-

ing pattern. If power is increased above that for maximum endurance, efficiency in terms of miles per gallon of fuel burned will increase. Aircraft speed will increase at a greater rate than the increase in fuel consumption due to the more efficient flight attitude. Thus, for any flight the elapsed time is reduced and less total fuel will be burned than if operations were continued at maximum-endurance power. Once cruising altitude is reached, the actual power currently being used to hold an airspeed may be computed with the Travel Air's horsepower calculator. Thus, fly an airspeed or power setting — then check your performance through the calculator and graphs. Remember, the calculator is based on outside air temperature as read from the free air instrument.

## **MANEUVERS**

Your Travel Air is licensed under normal category limitations and is intended for only nonaerobatic passenger and cargo operation. Only those maneuvers incidental to NORMAL flying including stalls (except whip stalls) and turns in which the angle of bank does not exceed 60° are permitted. Refer to Section III for maneuver and stall speeds.

During a normal stall approach, a slight buffeting will provide a sufficient warning to permit a normal recovery; the severity of this warning will increase slightly with power on. In addition, the stall warning indicator gives aural indication of an impending stall approximately five to ten mph above the actual stall.

If a spin is entered inadvertently, cut the power on both engines. Apply full rudder opposite the direction of rotation and then move elevator forward until rotation stops. When the controls are fully effective, bring the nose up smoothly to a level flight attitude. Don't pull out too abruptly.

Because of the Travel Air's clean design, speed is picked up rapidly in a nose-low attitude. Speed should be carefully controlled, especially if a "red line" speed is approached or rough air encountered unexpectedly. During a pull-out be aware of the amount of control pressure you must use to complete a safe recovery in the altitude you have available, and the load you can apply to the structure in a pull-out. Avoid any abrupt maneuvering or sudden application of the controls during this "red line" condition.

## **FLIGHT THROUGH TURBULENT AIR**

When flight through a storm area or extremely rough air cannot be avoided, the problem becomes one of choosing the correct airspeed for safe operation under your present weight configuration. If you maintain a high airspeed, structural damage or complete failure may result; yet you must maintain sufficient airspeed for full control.

Your safe operating range between the two danger zones varies with the severity of the gusts: the stronger the gusts, the narrower your safe operating range. Refer to the penetration speed graphs in Section VI.

Once you have established your chosen airspeed and trimmed for level flight, you can increase the stability of the aircraft still more by extending the landing gear; the landing gear may be lowered at speeds up to 200 miles per hour (174 knots) IAS, as an extreme emergency measure. If you lower the landing gear as an aid to reducing your speed, you should be alert for the changes in spiral control, elevator trim, and rate of sink. Lower the gear while in level flight, to avoid excessive speed build-up rather than as a corrective measure once the airplane is in a dive.

### **NOTE**

After extending the landing gear at high speed, the landing gear doors and supporting structure should be inspected for possible damage.

Do not lower the flaps however, unless you are letting down.

Switch to the main fuel cells, since you may encounter abrupt and severe changes in altitude and attitude as you fly through the turbulence.

## **DESCENT**

Your preflight planning should have determined the procedure you intend to use. Generally, a slow cruising descent starting well out from your destination is more comfortable and, with the higher cruising speed attained during the shallow descent with reduced power settings, an over-all savings in fuel will result. Adverse weather, however, if encountered at these lowering altitudes might nullify these advantages

and make a sharp rate of descent more profitable; therefore, pilot preference and weather will determine the rate of descent.

Throughout descent watch your engine temperatures and regulate the cowl flaps accordingly, since temperatures may go below a safe minimum for full power which you may need during your approach and landing. During the final portion of the let-down and prior to traffic pattern entry, perform the "before landing" check items listed in Section II.

### **NORMAL LANDING**

The approach speed on final is governed by changing wind conditions, aircraft loading, weather, pilot technique, etc. As you cross the end of the active runway, start decreasing the power settings to idle rpm and maintain sufficient back pressure to hold a slightly nose high attitude just off the runway. As airspeed is dissipated, constantly increase back pressure until the aircraft settles to the runway in a nose high attitude just as stalling speed is reached. Touchdown should be on the main wheels with only partial relaxation of back pressure. As speed continues to diminish, back pressure may be slowly relaxed and the nose wheel lowered gently to the runway. Apply brakes only after the nose wheel is down and avoid any hard braking action unless absolutely necessary. On any landing, retract the wing flaps near the end of the landing roll. Set the elevator trim to a "0" reading and open the cowl flaps.

During high altitude landing operations, watch your airspeed closely. Don't attempt to estimate your actual speed from your rate of ground travel. While the required IAS for maneuvering at high altitude will not change, the allowances you must make in take-off and landing distances will be almost doubled at an elevation of 6,000 feet as compared to the same conditions at sea level. This is due to the decrease in air density as altitude increases. The exact allowance increases you must use for your particular altitude, temperature and loading may be seen by studying the performance graphs provided for this purpose.

### **NIGHT LANDING**

The pre-landing procedures for night operation are the same as used

during a normal landing with the exception of using the different lighting elements. Many experienced pilots prefer power usage completely through the approach, flareout and actual touchdown, which is most desirable when it is difficult to estimate the aircraft's exact altitude as is often the case without runway lights. By holding this partial power the aircraft will settle to the runway in a semi-power stall; just as the ground is contacted the power should be cut off. At any time during a power-on approach, simply by increasing power, the rate of descent may be reduced sharply to allow for errors in judgment or a go-around if necessary.

The use of landing lights is not always entirely beneficial, as a certain glare is associated with their use, especially in haze conditions; however, if you decide to use the landing light, it should be turned on while the aircraft is well above the ground, in order to avoid sudden changes in the appearance of the landing area as the landing position is approached. To prevent overheating, avoid prolonged use of the landing light during ground maneuvering.

### **ENGINE SHUTDOWN**

Check all instruments for readings within specified limitations; advance the throttles to an engine speed of approximately 1,100 rpm. Position the propeller controls in low pitch (high rpm), turn off the auxiliary fuel pumps (if in use) and pull the mixture controls back to the idle cut-off position. As the engines slow, move the throttles to the full aft position until the engines quit firing. Switch off the magneto switches after the propellers have stopped rotating. Check the panel for all desired switches and controls in the "OFF" position. Fuel selector valves may be turned off.

### **COLD WEATHER OPERATION**

In addition to the normal preflight exterior inspection, remove ice, snow, and frost from the wings, tail, control surfaces and hinges, propellers, windshield, fuel cell filler caps, fuel vents, and crankcase breathers. If you have no way of removing these formations of ice, snow, and frost, leave the aircraft on the ground as these deposits will not blow off. The wing contour may be changed by these formations sufficiently that its lift qualities are considerably disturbed and sometimes completely destroyed. Complete your normal preflight pro-

cedures, including a check of the flight controls for complete freedom of movement.

Conditions for accumulating the moisture, in both the engine oil sumps and the fuel cells, are most favorable at low temperatures, due to the condensation increase in the fuel cells and the moisture that enters as the systems are serviced. Therefore, close attention to draining the fuel cells and oil sumps will assume particular importance during cold weather.

Engine oil viscosity weights should be changed according to the oil weight as shown in the Consumable Materials Chart in Section VII, provided a sufficient amount of your flying is going to be in cold weather. Always pull the propeller through by hand several times to clear the engine and "limber up" the cold, heavy oil before using the starter. This also will save battery energy if an auxiliary power unit is not available.

Under very cold conditions, it may be necessary to preheat the engines prior to a start. Particular attention should be applied to the oil cooler and sump to insure proper preheat, since congealed oil in these areas will prevent proper lubrication of the engines. A start with congealed oil in the system may give an indication of normal pressure immediately after the start, but then the oil pressure may decrease when residual oil in the engine is pumped back to the congealed oil in the sump. If an engine heater capable of heating both the sump and cooler is not available, the oil should be drained while the engines are hot and stored in a warm area until the next flight.

If your Travel Air is equipped with the optional external power receptacle, it is advisable to use external power for starting, when available, since cold weather decreases battery efficiency. The external power unit should be equipped with the standard AN fitting or an adapter, to insure proper connection. Set the unit's output at 27 to 28.5 volts and make the plug-in. To prevent arcing, be sure that no power is supplied to the plug when it is mated. The plus terminal of the external power receptacle is wired to the bus side of the battery relay, which allows the starter to be energized with the battery master switch off. Refer to Section VII for detailed information concerning use of external power.



Normal cold weather starting procedures will ordinarily be used. This may require somewhat more extensive use of the auxiliary fuel pump. If there is no oil pressure within the first thirty seconds of running, or if the oil pressure drops after a few minutes of ground operation, shut down the engine and check for broken oil lines, radiator leaks or the possibility of congealed oil.

Avoid taxiing through water, slush, or muddy surfaces if possible. Water, slush, or mud splashed on the wing and tail surfaces may freeze, increasing weight and drag and perhaps limiting control surface movement.

On wet or icy runways, use your brakes with extreme caution; taxi slowly for best control.

During warm-up, watch your engine temperatures closely, since it is quite possible to exceed the cylinder head temperature limit in trying to bring the oil temperature up. Exercise the propellers several times to flush cold oil from the pitch change mechanisms. Turn on the pitot heat to remove any ice that may have formed.

During in-flight operation, cycle the propellers through their pitch range several times to flush cold oil from the actuating cylinders.

On flights that take you into areas where icing conditions may be anticipated, turn on the propeller anti-icer (optional equipment) to wet the propeller blades BEFORE icing conditions are encountered. The anti-icer fluid pump, which delivers a constant flow of fluid to the propeller blades, is controlled by an ON-OFF switch on the electrical panel. Endurance of the anti-icer system is approximately two hours of operation.

Remember, however, that the propeller anti-icer is designed to prevent icing, not to remove ice once it has built up. Be sure to prepare your propellers for icing conditions prior to exposing them to ice.

To provide maximum safety of flight during cold weather, you may have had your Travel Air equipped with the optional lightweight, pneumatic deicer system. If icing conditions cannot be avoided, allow ice to build up on the leading edges of the various airfoils before

actuating the system; then pull the deicer reservoir shut-off valve control fully out and actuate the cycling valve control which will inflate the deicer boots to destroy the ice build-up. When the inflation-deflation cycle of the boots is complete, discontinue the use of the system until ice again builds up.

As an aid to effective, economical operation of the deicer system, your attention is invited to the tabulations in Section III which detail the system's endurance with respect to reservoir pressure and deicing cycles available at those pressures.

To insure static air for proper instrument function in severe icing conditions, each airplane equipped with a surface deicer system incorporates an alternate static air source. Should ice or other foreign matter obstruct the static air ports on the fuselage, with the storm window closed, place the emergency static air source control handle in the "OPEN" position.

Since the alternate static air source is an emergency system, some inconsistency with normal instrument readings may be expected.

Generally, airspeed and altimeter readings will be somewhat higher than normal, but these instrument variations have been carefully computed and are provided for you in the FAA Approved Flight Manual Supplement that is supplied with each airplane equipped with an emergency static air source installation.

The emergency static air valve should be kept completely closed except when the source is required.

During your let-down and landing in cold weather operation, complete the normal checks and procedures, giving special attention to the engine temperatures which will have a tendency toward over-cooling.

## **INDUCTION SYSTEM ICE**

One of the chief advantages of fuel injection for an aircraft engine is its freedom from induction system icing. Extensive tests have shown that the only icing problem to be expected is impact ice forming on the

air intake and filter. A spring loaded door on the bottom of the induction system air box will suck open automatically in the event the air intake and filter is clogged with ice or other material. A manually operated alternate air control is also provided which operates a damper in the induction system; when closed, the damper will cause the spring loaded door to suck open. It is suggested that the alternate air control be pulled out under conditions when induction system impact icing appears likely. You will notice only a slight drop in manifold pressure due to loss of ram effect.

## **HOT WEATHER OPERATION**

Hot weather, particularly when combined with high elevation field operation, may produce sufficient vapor to cause oscillations in the fuel flow gage. The engine operation is not noticeably affected. This problem may be reduced by observing the following procedures:

1. Avoid prolonged ground operation. When holding on ground, use 800-1000 rpm to provide better cooling.
2. During start and warm-up, use the auxiliary cells. Return the selectors to main cells for pre-take-off checks and for take-off.
3. Select a fuel flow (use boost pumps) appropriate to your altitude and power setting both on the ground and in flight.

## **OXYGEN SYSTEM (OPTIONAL)**

### **WARNING**

Oxygen under pressure is a friend when properly used but becomes an enemy when normal precautions are disregarded. Since oxygen supports combustion, proper safety measures must be employed when using it or a serious fire hazard is created. **MAKE CERTAIN THAT ALL CIGARETTES ARE COMPLETELY EXTINGUISHED BEFORE USING THE SYSTEM** and warn your passengers of the dangers of smoking while oxygen is being used.

1. To place the oxygen system in operation, slowly open the shut-off

valve on the oxygen console panel. (The shut-off valve on the oxygen cylinder must also be open.)

### CAUTION

If either shut-off valve is opened too rapidly, the regulator diaphragm may be ruptured, or other damage common to high pressure oxygen systems may occur.

2. Insert an oxygen mask plug-in coupling into an oxygen outlet.
3. Check for a flow of oxygen into the mask by closing off the opening from the breather bag to the mask and noting that the bag expands. Changes in flow rate will be made automatically with changes in pressure altitude.
4. Adjust the oxygen mask to the face to prevent the escape of oxygen into the cabin.
5. To discontinue use of the oxygen system, close the shut-off valve on the oxygen console panel, and with one or more masks still plugged in, allow the oxygen to drain from the low pressure side of the system, then unplug all masks.

### INSTRUMENT FLIGHT

Properly equipped, your Travel Air is an instrument airplane, but are you an instrument pilot? Even the most careful VFR pilots occasionally will encounter weather conditions beyond their piloting skill, and for this reason a technique perfected by the University of Illinois Institute of Aviation should be made a part of your own skill. Known as the "180-Degree Turn," it is a technique designed to return the VFR pilot to VFR conditions, safely.

Essentially, the technique consists of (1) increasing drag by lowering the gear — *in an extreme emergency the gear may be lowered at speeds up to 200 miles per hour (174 knots) IAS*; (2) reducing airspeed; (3) trimming the airplane for a predetermined slow-flight speed; (4) **WITH THE HANDS OFF THE WHEEL**, making a turn with the rudders only, to a heading of 180° from the heading on which you were flying when you lost visual contact.

This technique is simple, but rapid, smooth and precise execution is essential to its success, and you should learn it from a qualified instructor, preferably in your own airplane, so that it can become completely familiar and automatic. We suggest that you contact the University of Illinois for more precise details on this procedure.

Always operate your Travel Air so that you and your passengers are comfortable; discomfort will usually appear well in advance of danger. Remember — the final responsibility for safe flight falls squarely upon your shoulders as the pilot.

## **SECTION V**

# ***Unusual Operating Conditions***

“The best time to know procedures and the worst time to practice them is during an emergency.”

Emergencies created by the failure or malfunction of one or more components or accessories may be broadly classified in one of two groups: those requiring immediate action and those in which you have sufficient time to decide on and execute a plan of action according to the demands of the particular situation.

In this discussion of emergencies the situations requiring immediate corrective action are treated in check list style for easy reference and familiarization. Other situations are discussed with respect to cause, condition, effect, and possible corrective measures. Your practice of these suggested techniques should be frequent enough for you to maintain proficiency in the rapid initiation of the proper procedures. Complete mastering of the emergency procedures peculiar to multi-engine flying cannot be overly stressed.

Emergency situations seldom will occur if you follow good inspection and maintenance practices; otherwise, your need for a complete understanding of this section is multiplied.

### **SINGLE-ENGINE OPERATION**

The flight and handling characteristics of your Travel Air on one engine are excellent. The aircraft may be safely maneuvered or trimmed for normal hands-off operation, which is easily sustained by the operative engine as long *as sufficient airspeed is maintained*. However, to properly use these safety and performance characteristics, you must have sound understanding of single-engine performance and the limitations resulting from an unbalance of power.

Two major factors govern the single-engine operation: airspeed and directional control. The minimum single-engine control speed is the speed at which you still have directional control with the aircraft in take-off configuration, one engine inoperative and full take-off power on the operating engine. However, bear in mind that this speed is a minimum for control and *below the speed at which the aircraft will climb*.

The best single-engine rate-of-climb speed at sea level is indicated by the blue line on the airspeed indicator. This speed is extremely important for best performance in an emergency. If this speed is allowed to vary from the optimum, your rate of climb will decrease, or if you are above the critical single-engine altitude, your rate of sink will increase. If you have best single-engine rate-of-climb speed, normal single-engine procedures may be followed. Otherwise, you must attain this necessary airspeed through an altitude loss or make a landing. The technique to be used in a given situation and the decisions you must make will depend entirely upon your altitude and airspeed at the particular time the emergency arises. The variation in best rate-of-climb speed with altitude is shown in the graphs in Section VI.

Airspeeds given in Section III and Section VI are recommended for average piloting techniques, under average conditions; they do not represent the maximum aircraft performance under ideal conditions, but have been determined on the basis of actual flight tests to afford you with a reasonable margin of safety.

The chief advantage of an additional engine is the ability of the aircraft to go on flying if one engine fails. However, having two engines, like having blind flying instruments, is a safety factor which depends on the knowledge, technique and the recent experience of the pilot in his particular airplane.

A zero thrust graph with instructions for simulated one engine out conditions is provided to aid in reduction of risks involved in single-engine practice. Practice these techniques until they become instinctive.

## **SIMULATED SINGLE-ENGINE PROCEDURE**

Simulated single-engine conditions may be set up whereby zero thrust power settings may be used instead of complete engine shut-

down in order to avoid the risks involved in the training or practice of single-engine technique. The two airspeeds represented in the accompanying graph are  $V_{mc}$ , minimum single-engine control speed, and  $V_y$ , best single-engine rate-of-climb speed, with the landing gear up and the propeller feathered. In order to set up a zero thrust condition for single-engine practice, use the following procedure:

### Use of the Zero Thrust Graph

1. Select your pressure altitude (altimeters set at 29.92 inches Hg) and either the  $V_{mc}$  or  $V_y$  airspeed.
2. Observe the OAT and determine the standard altitude from the altitude conversion chart.
3. To find the correct engine rpm, read horizontally across the zero thrust graph at the standard altitude, calculated in step 2, to the selected airspeed where it intersects the airspeed curve. Then read the engine rpm directly below.

ENGINE SPEED FOR ZERO THRUST AT ALTITUDE

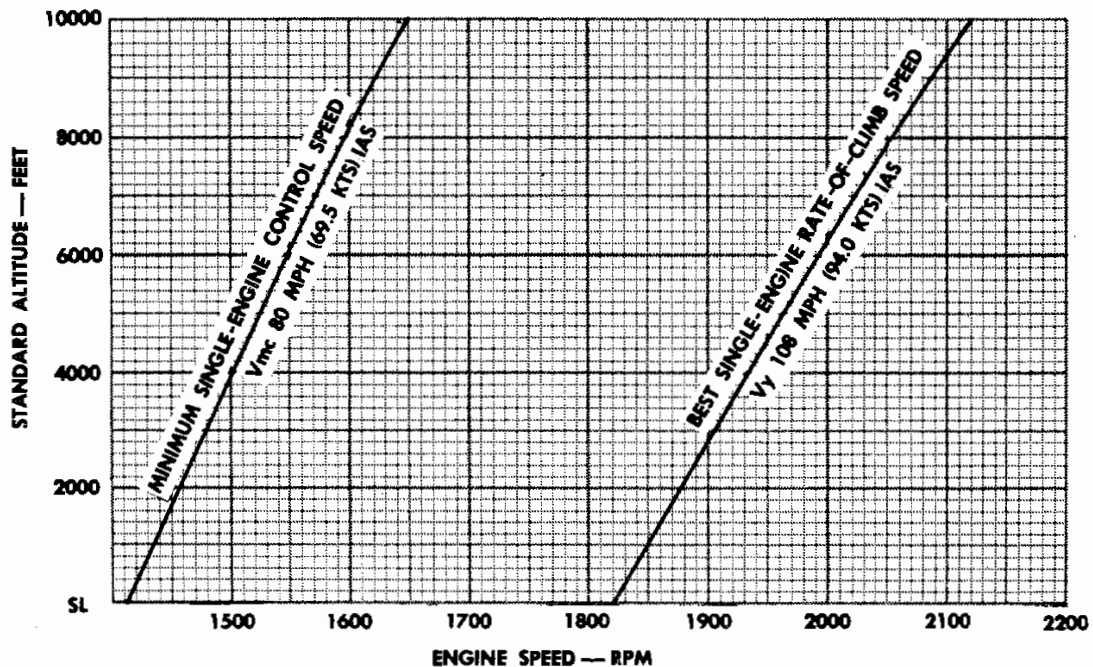



## **Application**

1. To obtain zero thrust rpm, adjust power to minimum throttle setting for the required rpm and airspeed, with the prop control in the FULL HIGH RPM position.

2. After setting up the above zero thrust practice conditions, single-engine flight characteristics will be as set forth in the following paragraphs. The engine speed for obtaining zero propeller thrust can be affected quite markedly by variations in atmospheric conditions and indicated airspeed. Care should be exercised in determining the standard altitude and setting up the zero thrust power at the proper rpm and minimum manifold pressure at the airspeed for the given condition.

3. For recovery after the practice condition, apply throttle and retrim as necessary.

## **Determining Inoperative Engine**

Once an engine has actually failed, your first consideration is to continue to fly the aircraft. Apply all available power immediately; *all six levers full forward*. Then determine for certain which engine has failed, since there is a chance you may feather the propeller on the good engine. The following checks will aid you in deciding which engine has failed:

1. *Dead foot—dead engine*. The rudder pressure required to maintain directional control will be on the side of the good engine.

2. *The cylinder head temperature gage* immediately will indicate a lower than normal reading for the inoperative engine.

3. *Partially retard the throttle* on the engine that is believed inoperative. There should be no change in control pressures or in the sound of the engine, if the correct throttle has been selected. Under conditions of low altitude and IAS, this particular check must be accomplished with extreme caution.

Never try to determine the inoperative engine by reading the tachometer or the manifold pressure gage. After power has been lost on an engine, the tachometer often will indicate the correct rpm and the manifold pressure gage frequently will indicate approximate atmospheric pressure or above.

## **NORMAL SINGLE-ENGINE PROCEDURE**

After determining the inoperative engine, if your IAS is at or above best single-engine rate-of-climb speed, use the following shutdown procedure. The over-all goal of the steps is to reduce all unnecessary drag in as short a time as possible.

1. Apply take-off power (throttles, propellers and mixtures for both engines FULL FORWARD), to obtain or maintain desired altitude and airspeed; apply rudder to maintain directional control. Bank approximately 5 degrees into the heavy rudder.

2. Retract the landing gear.

3. Pull the propeller and mixture controls back into the full feathered and idle cut-off positions for the inoperative engine.

4. Close the cowl flaps on the inoperative engine. Retract wing flaps gradually if in use.

5. As the propeller feathers and the engine stops rotating, shut off generator and ignition switches. If propeller fails to completely stop, decrease airspeed slightly.

6. Turn fuel selector valve for inoperative engine to OFF.

7. Turn off unnecessary electrical equipment to prevent battery drain.

8. Maintain take-off power until a safe altitude is attained or until single-engine procedures and checks are satisfactorily accomplished. Select a cruise power setting for the good engine to maintain minimum speed for hands-off trim on one engine.

9. Set rudder trim for single-engine flight and trim wing on the inoperative engine side to hold 3 to 5 degrees high.

10. Land as soon as practicable.

## **ENGINE FAILURE DURING TAKE-OFF**

Before each take-off it is suggested that you consult the accelerate-stop graph in Section VI to determine your decision speed and deceleration distance for the maximum load condition. Due to the many variables involved, it would be impractical to try to prepare corrective procedures for every situation possible. However, we have prepared a

list of the most common conditions that might develop, followed by the recommended corrective action.

To pinpoint the meaning of the terms used in the procedures, we have included the following definitions:

*Minimum Single-Engine Control Speed* — The airspeed below which the airplane cannot be controlled in flight with one engine operating at take-off power and the other engine with its propeller windmilling.

*Best Single-Engine Angle-of-Climb Speed* — The airspeed which delivers the greatest gain in altitude in the shortest possible horizontal distance with gear up, flaps up, and inoperative propeller feathered.

*Best Single-Engine Rate-of-Climb Speed* — The airspeed which delivers the greatest gain in altitude in the shortest possible time with gear up, flaps up, and inoperative propeller feathered.

The specific data for the terms above are given in Section III, Performance, or in Section VI, Operational Data.

Engine Failure Occurs During Take-Off:

A. If there is sufficient runway remaining for deceleration — CUT POWER IMMEDIATELY AND STOP STRAIGHT AHEAD.

B. If there is insufficient runway remaining and you have not gained best single-engine angle-of-climb speed — USE THE FOLLOWING PROCEDURE:

1. THROTTLES CLOSED.
2. BATTERY AND GENERATOR SWITCHES — “OFF.”
3. FUEL SELECTORS — “OFF.”
4. CONTINUE STRAIGHT AHEAD, TURNING TO AVOID OBSTACLES IF NECESSARY.

C. If there is insufficient runway remaining and you have gained best single-engine angle-of-climb speed and are airborne — IMMEDIATELY CLEANUP THE AIRPLANE (RETRACT LANDING GEAR, FEATHER WINDMILLING PROPELLER) AND FOLLOW NORMAL SINGLE-ENGINE PROCEDURE:

## **NOTE**

With the airplane clean you can climb. With gear down, propeller windmilling and cowl flaps open, you will not be able to maintain altitude.

1. If it is necessary to clear obstacles — cleanup airplane and maintain best single-engine angle-of-climb speed.
2. If no obstacles are present, cleanup airplane and accelerate to best single-engine rate-of-climb speed.
3. After obtaining the best single-engine rate-of-climb speed, return for landing.

Bear in mind also that the performance shown on the single-engine climb graph is for standard altitude; if your ambient temperature is higher than standard, your rate of climb will be less than that shown, while on a cold day it will be better. The amount of these variations may be visualized by selecting a few different ambient conditions of temperature and pressure, and checking the performance as shown on the graph.

## **ENGINE FAILURE DURING FLIGHT**

Follow normal single-engine procedures if the difficulty is apparent and cannot be remedied. Otherwise, if you have a safe altitude, the following checks may be accomplished in addition to the normal procedures. These checks should be made prior to feathering the propeller and turning off the ignition switches on the inoperative engine.

1. Check fuel flow; if insufficient, turn on the auxiliary fuel pump.
2. Check fuel quantity; switch to another cell if necessary.
3. Check oil pressure and temperature indications; shut down the engine if oil pressure is low.
4. Check ignition switch.

## **RESTARTING INOPERATIVE ENGINE**

Prior to a restart of an engine that has failed, the cause of failure should be located and corrected. It is wiser to continue on one engine than chance ruining an engine that may need only minor repairs.

During cold weather, your restarts should be completed within a few minutes after shutdown, since cold oil in the governor passages and propeller may impede unfeathering.

For engine to be started:

1. Turn fuel selector valve to either MAIN or AUXILIARY position.

2. Adjust throttle to normal starting position.

3. Move propeller control well into the governing range.

4. If the airplane is not equipped with unfeathering accumulators, turn on the auxiliary fuel pump and when fuel flow is indicated, engage starter.

5. When propeller unfeathering accumulators are installed, momentary use of the starter to initiate rotation will be necessary only at low airspeeds.

6. After several engine revolutions, advance mixture control to FULL RICH.

7. If engine fails to run and unfeather, it may be necessary to turn auxiliary fuel pump off and place mixture control in IDLE CUT-OFF position to clear engine of excessive fuel.

8. As soon as engine starts, adjust throttle and propeller controls to prevent an engine overspeed condition. Check for fuel flow and oil pressure. If either indicator does not respond normally, abandon attempt at starting. Refeather and secure engine.

9. After engine starts, warm up at approximately 2000 rpm and 15 inches manifold pressure. Observe oil pressure closely; if not normal within first 30 seconds, shut down and refeather.

10. When oil temperature is in the normal range, bring engine up to normal power. Set rpm first, then open throttle. Retrim.

## **SINGLE-ENGINE LANDING**

Essentially, a single-engine landing is the same as a normal landing, except that you should allow a larger safety margin during the pre-landing pattern and final approach. This safety margin is in the form of more airspeed, a slightly higher pattern and final approach altitude, and a wider pattern which will eliminate any steeply banked turns.

Since you have more altitude, your final approach may be higher and because of the larger pattern you may line up with the runway further out; thus you will have time to correct for any wind drift, stabilize your final approach speed and rate of descent and judge more accurately your use of gear and flaps. Also, you can ease off the power on your good engine a little sooner; rudder trim should be reduced to neutral as power is decreased.

Lower the landing gear only after final approach is established. If a base leg is used, the gear may be lowered as you roll out of the turn on final; in making a straight-in approach aim for the first few feet of runway and set up a glide path to overshoot rather than undershoot, then lower the gear. Do not lower the flaps until the gear is down and locked and you are sure of making the field. Full flaps may be used to shorten the landing roll or to steepen the approach if you are overshooting.

With full flaps and gear down, level flight cannot be maintained at full gross weight on one engine; unless time will permit you to clean up the airplane, do not attempt to go around.

### **SINGLE-ENGINE GO-AROUND**

*A single-engine go-around may be executed when it appears this is the only way to avoid a possible accident. The following procedure should be used and rapid execution of the individual steps is very important:*

1. Apply full power and correct for yaw as the throttle opens. Maintain best single-engine rate-of-climb speed.
2. Retract the landing gear and close cowl flaps on dead engine.
3. If flaps are full down, retract to approximately half flap.
4. Retract the remaining flap as soon as practicable to obtain maximum rate of climb.
5. Trim for single-engine climb.

### **SINGLE-ENGINE OPERATION ON CROSSFEED**

The suction type crossfeed system enables the operating engine to use the entire fuel supply of either wing. Once you have completed your single-engine procedures, if you desire to use the fuel in the

opposite wing cells, turn the fuel selector valve handle for the operating engine to crossfeed and the dead engine selector handle to the desired fuel cell, either main or auxiliary. An interlock prevents both fuel selector valves being placed on crossfeed at the same time, which would cut off the fuel supply for both engines. The crossfeed system is designed for level flight only.

Normally, the engine will operate satisfactorily from crossfeed, but if necessary, the auxiliary fuel pump for the operative engine may be turned on to supplement the fuel injector pump.

### **CROSSWIND TAKE-OFF**

Crosswind take-off procedures differ from into-the-wind technique only during the latter part of the take-off run and during the actual lift-off. Wing flap and trim tab settings correspond to a normal take-off operation. As flying speed is gained, apply forward pressure on the control wheel to keep the nose gear solidly on the ground for positive directional control. Counter the crosswind action by holding the wings level with the ailerons. When you have attained lift-off speed, pull the aircraft off with a definite back pressure on the control wheel; relax aileron and rudder pressures to allow the aircraft to establish its own crab angle. This will effect a straight track in reference to your ground roll.

### **OBSTACLE TAKE-OFF**

When a maximum of altitude in a minimum of forward distance must be attained, use 20 degrees of wing flap and set the elevator trim between "0" and 3 points "nose up," as required; apply full power and release the brakes. Hold the wings in a near level flight attitude during the take-off run, until lift-off speed is attained, then smoothly and positively apply back pressure to assume a nose-high climb angle. After you have positively cleared the ground, retract the landing gear and maintain the nose-high attitude to obtain the maximum angle of climb until the obstacle is cleared. The best angle-of-climb speed will allow you to climb clear of an obstruction in the shortest distance. After you are in the clear, level off and accelerate to normal climb speed and retract the wing flaps.

### **OPERATION FROM UNIMPROVED FIELD**

To get the aircraft airborne in the shortest forward distance traveled,

under less than ideal surface conditions, use 20 degrees of wing flap and adjust the elevator trim from "0" to 3 points "nose up," depending on the loading; apply full power and release the brakes. The control wheel should be held well back during the beginning of the take-off run, to establish the maximum possible angle of attack. As the take-off run progresses and landing gear drag decreases, the angle of attack should be gradually reduced for better acceleration to flying speed. As you become fully airborne, relax back pressure to permit the aircraft to accelerate, and retract the landing gear. Retract the wing flaps as normal climb speed is attained.

To land the aircraft in the shortest forward distance, use full flaps and approach with as little power as practicable. Cross the approach end of the runway with a slightly nose-high attitude and dissipate the remaining altitude and airspeed with throttle and elevator coordination in such manner as necessary to cause the aircraft to touchdown in the shortest horizontal distance traveled, just as a stall is reached. The remaining procedure, after touchdown of the main gear, is determined by the type of landing surface used and available runway length.

### **OBSTACLE LANDING**

Your final approach must be higher than normal to clear the obstacle and allow you to set up your desired rate of descent. Use full flaps and maintain airspeed with elevator control and rate of descent with power. Hold airspeed within close tolerances as your sharp rate of descent will make it necessary to lead your normal flareout by a few extra feet of altitude; if necessary, add power. Lower the nose wheel immediately after the main gear touches down and apply the brakes as required.

### **CROSSWIND LANDING**

The recognized procedures for a crosswind landing are: slipping into the wind on final approach just enough to maintain a straight ground track and hold a heading to the intended landing strip, and by crabbing. Usually crabbing into the wind on final approach to correct for drift, and so maintain a straight track toward the landing strip, will handle a greater crosswind component than will the slipping approach. In addition, the crab method maintains normal glide angles and allows



the best view of the landing area.

Turn to the runway heading soon enough to prevent contacting the surface with the heading you used for drift correction.

### **BALKED LANDING**

Advance the throttles to take-off power and simultaneously apply sufficient pressure to control column to maintain a safe climb attitude for your present airspeed. Raise the landing gear, if you are solidly airborne. Raise the wing flaps. However, do not raise them rapidly when very close to the ground, because of the rapid loss of lift. Climb out at best rate-of-climb speed, until you can level off safely.

### **GEAR-UP LANDING**

If you are to make a gear-up landing, make a normal approach and if possible, choose a hard surface to land on. Use flaps as necessary. When you are sure of making the runway, close the throttles, move the mixture control levers to IDLE CUT-OFF, cut the battery master and all ignition switches, and turn the fuel selector valves to the OFF position. Keep the wings level and make the touchdown as gentle as conditions will permit. If possible, avoid a gear-up landing on soft ground, since sod has a tendency to roll up into chunks which may damage the aircraft structure.

### **LANDING GEAR EMERGENCY EXTENSION**



The landing gear handcrank will lower the gear manually if the electrical system fails or if you wish to do so for some other reason. The handcrank is designed only to lower the gear; you should not attempt to retract it manually. To preclude an excessive speed build-up, in an extreme emergency situation, the gear may be lowered at speeds up to 200 mph (174 knots) IAS.

## **NOTE**

After an emergency extension of the landing gear at high speeds, the landing gear doors and supporting structure should be inspected for possible damage.

Manually extending the gear will be easier if you can reduce your airspeed first. Use the following procedure:

1. Landing gear circuit breaker — pulled.
2. Landing gear switch — DOWN position.
3. Remove safety boot from handcrank handle (at rear of front seats). Turn counterclockwise as far as possible.
4. Check mechanical indicator to ascertain that gear is down.

If electrical system is operative also check your position light and warning horn.

## **ENGINE FIRE IN FLIGHT**

In case of fire in an engine compartment during flight, shut down the affected engine and follow normal single-engine procedures. Land immediately.

1. Fuel selector valve handle — OFF.
2. Mixture control — IDLE CUT-OFF.
3. Propeller lever — FEATHER.
4. Boost pump — OFF.
5. Ignition switch — OFF.
6. Generator switch — OFF.

## **MAXIMUM GLIDE**

Maximum gliding distance can be obtained by feathering both propellers and retracting the wing flaps, landing gear and cowl flaps. The glide ratio under this configuration, as shown in the Glide Distance Chart in Section III, is approximately two and one-half miles of gliding distance for every 1,000 feet of altitude.

## **SECTION VI**

# ***Operational Data***

All operational data, in the form of graphs or diagrams are grouped in this section of your owner's manual for quick easy reference. The data are grouped as nearly as possible in flight sequence and for your convenience an index is included below.

A carefully detailed and analyzed flight plan will enable you to realize the maximum benefit from your Travel Air. In using the graphs, bear in mind that allowances have been made for reserves and for fuel consumed in warm-up and taxiing; you must make allowances for variable factors such as winds as they actually exist from one flight to the next.

Having made a flight plan based on estimates taken from the graphs, you should check your actual performance and review the differences between your forecast conditions and actual conditions during the flight, so that your future estimates may be more accurate.

### **TABLE OF CONTENTS**

	<i>Page</i>
Normal Take-off .....	6-2
Short Field Take-off .....	6-4
Two Engine Time to Climb .....	6-6
Two Engine Climb Performance .....	6-7
Single Engine Climb Performance .....	6-8
Single Engine Emergency Rate of Climb .....	6-9
Fuel Consumption .....	6-10
Altitude Conversion .....	6-11
Cruising Operation .....	6-12
Manifold Pressure vs. RPM .....	6-13
Range Charts, Varying Power .....	6-14
Turbulent Air Penetration Speeds .....	6-18
Flight Load Factors .....	6-18
Accelerate and Stop Distance .....	6-19
Normal Landing .....	6-20
Short Field Landing .....	6-22

# NORMAL TAKE-OFF DISTANCE

DISTANCE OVER 50 FEET  
 GROSS WEIGHT 4200 LBS.  
 ZERO FLAPS  
 TAKE-OFF SPEED = 85 MPH/73.8 KTS (IAS)  
 — — STD TEMP

NO WIND

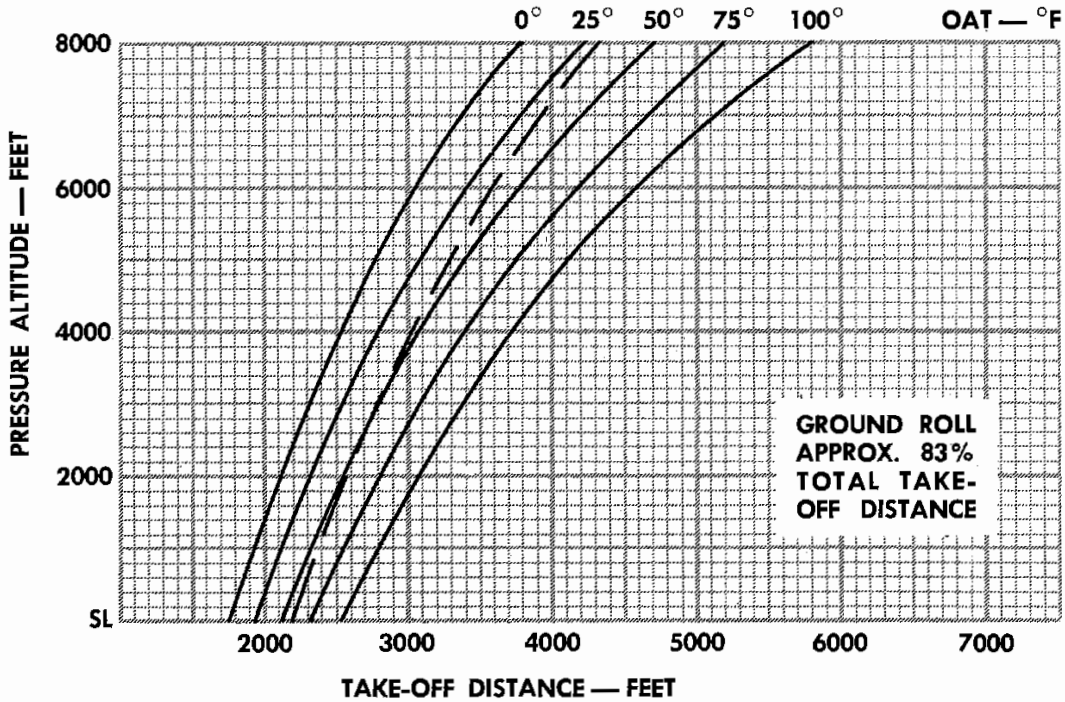

10 MPH/8.7 KTS HEADWIND

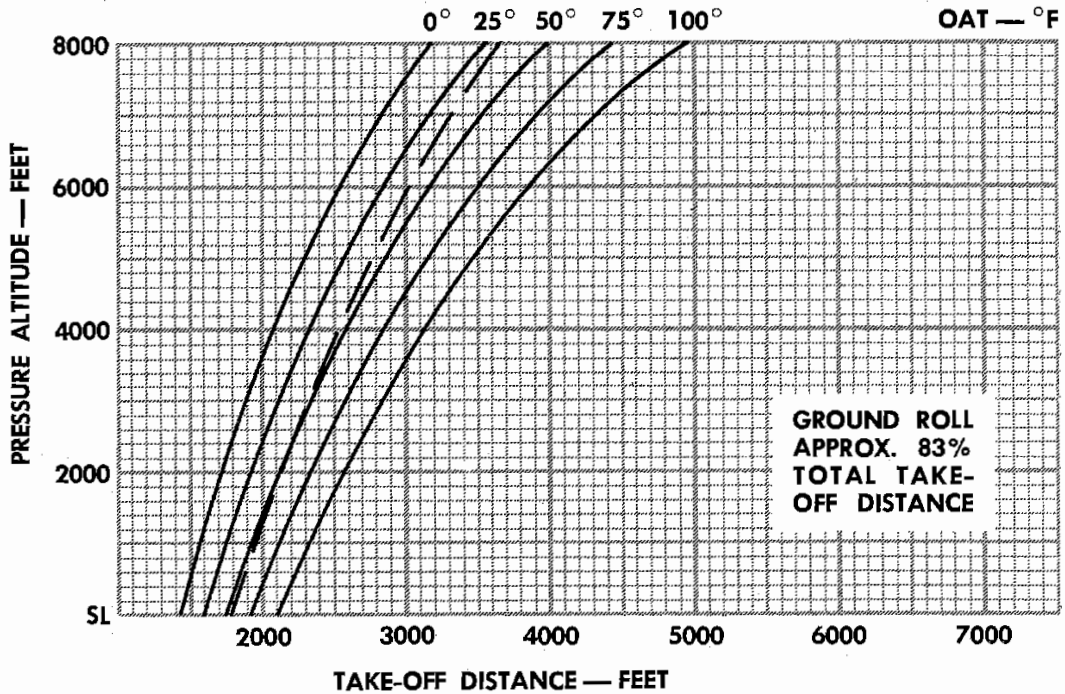

# NORMAL TAKE-OFF DISTANCE

DISTANCE OVER 50 FEET  
GROSS WEIGHT 4200 LBS.  
ZERO FLAPS

TAKE-OFF SPEED = 85 MPH/73.8 KTS (IAS)  
— — STD TEMP

20 MPH/17.4 KTS HEADWIND

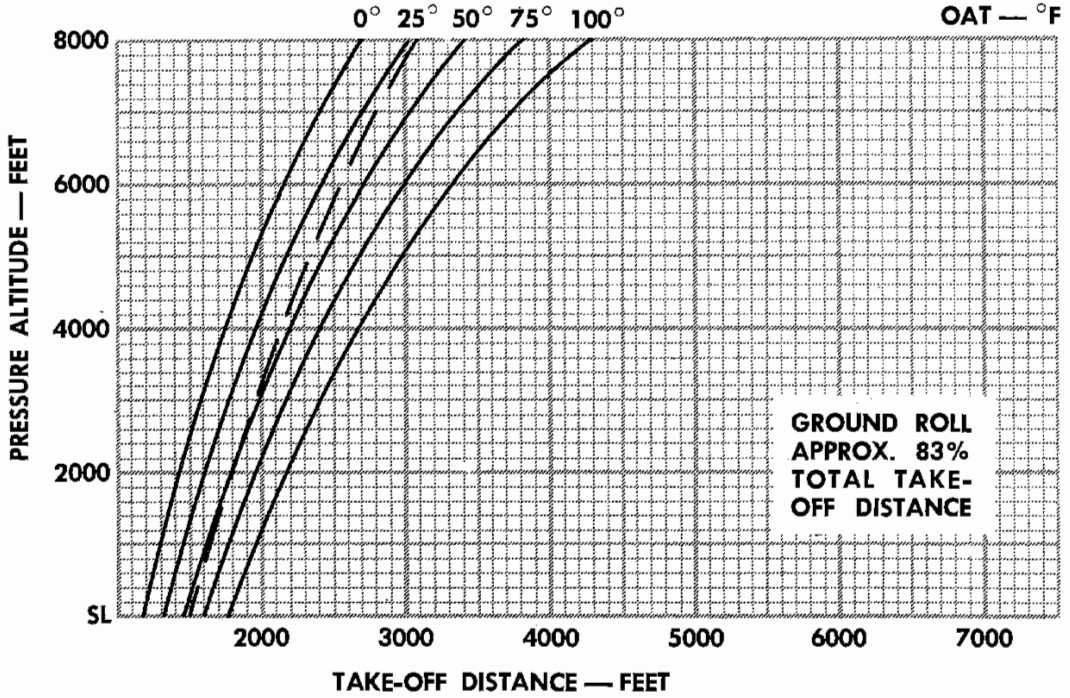

30 MPH/26.1 KTS HEADWIND

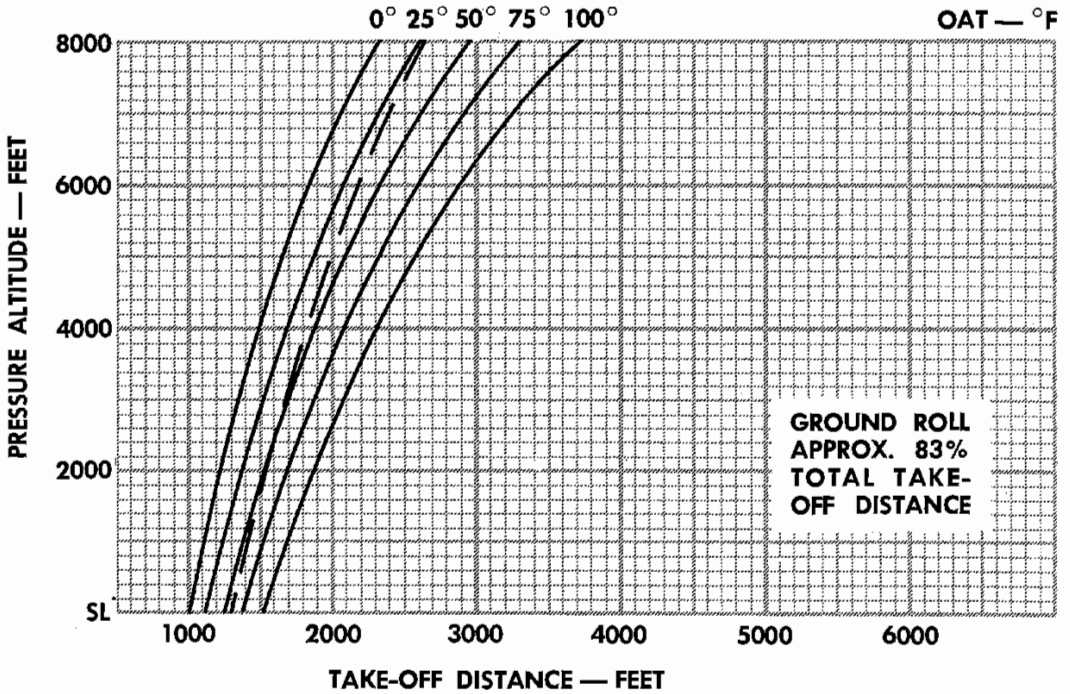

# SHORT FIELD TAKE-OFF

DISTANCE OVER 50 FEET  
 GROSS WEIGHT 4200 LBS.  
 FLAPS 20 DEGREES  
 TAKE OFF SPEED 70 MPH/60.8 KTS (IAS)  
 — — STD. TEMP.

NO WIND

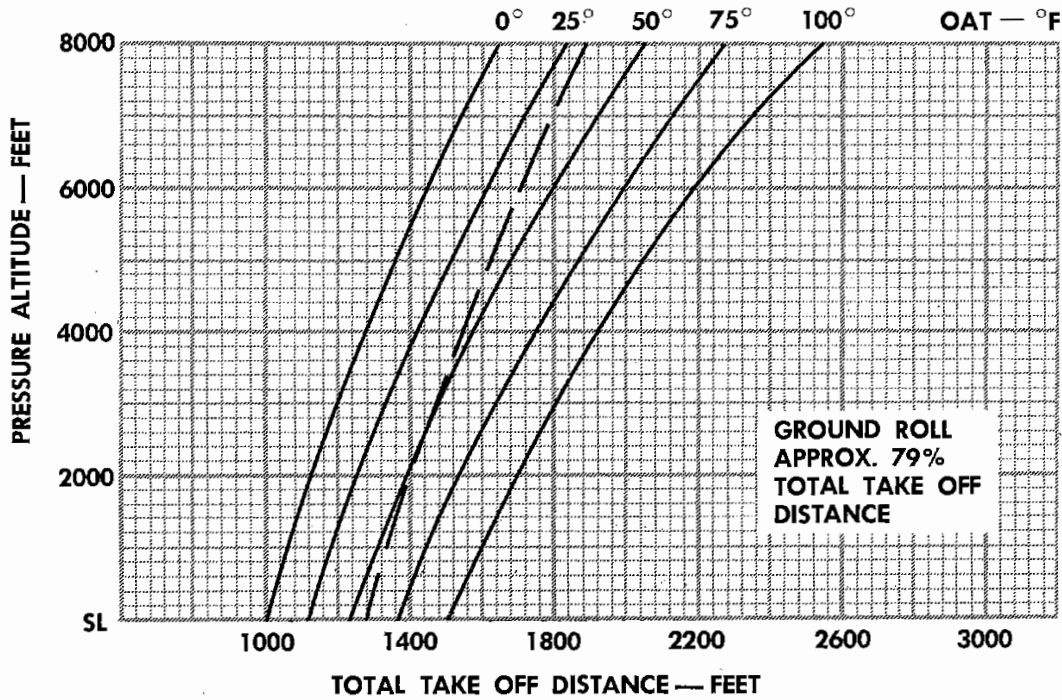

10 MPH/8.7 KTS HEADWIND

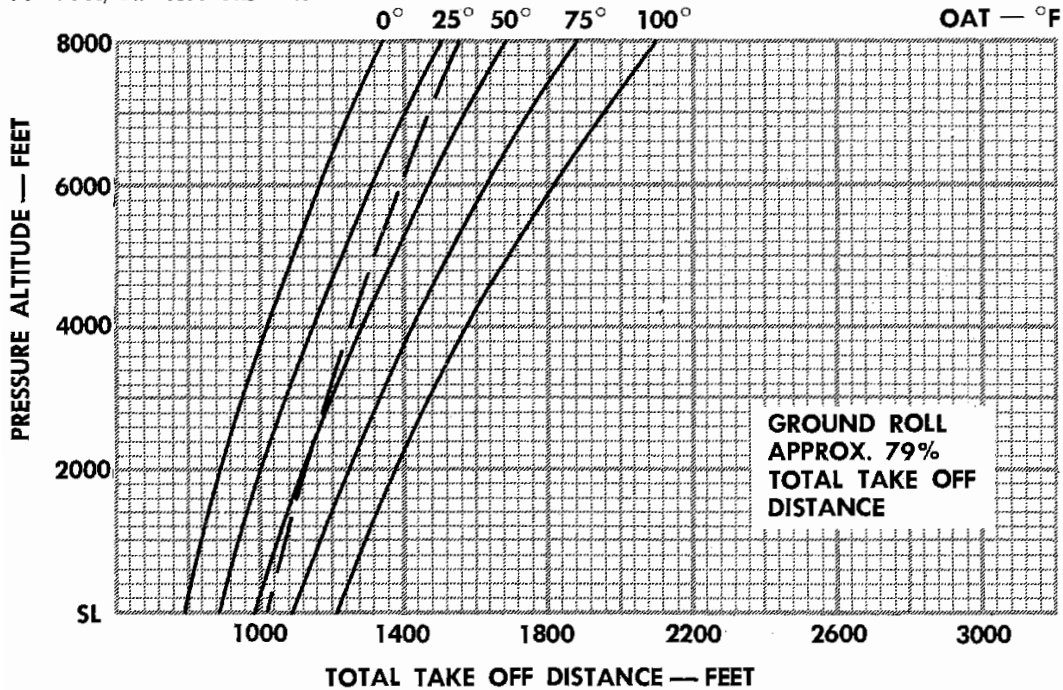

# SHORT FIELD TAKE-OFF

DISTANCE OVER 50 FEET  
GROSS WEIGHT 4200 LBS.

FLAPS 20 DEGREES

TAKE OFF SPEED 70 MPH/60.8 KTS (IAS)

— — STD. TEMP.

20 MPH/17.4 KTS HEADWIND

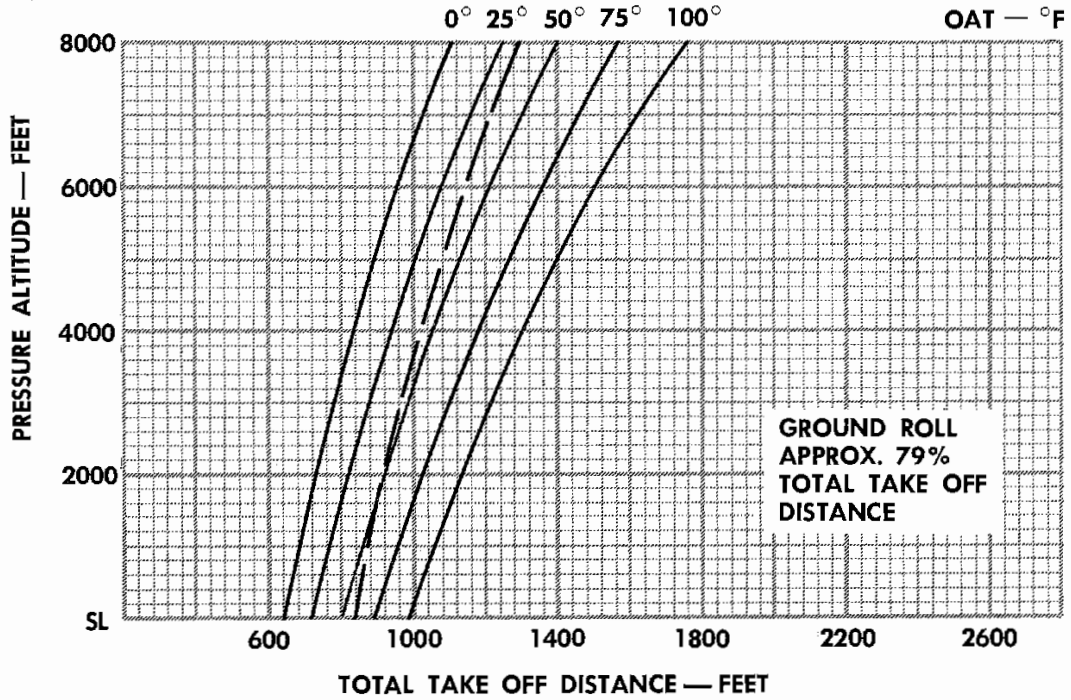

30 MPH/26.1 KTS HEADWIND

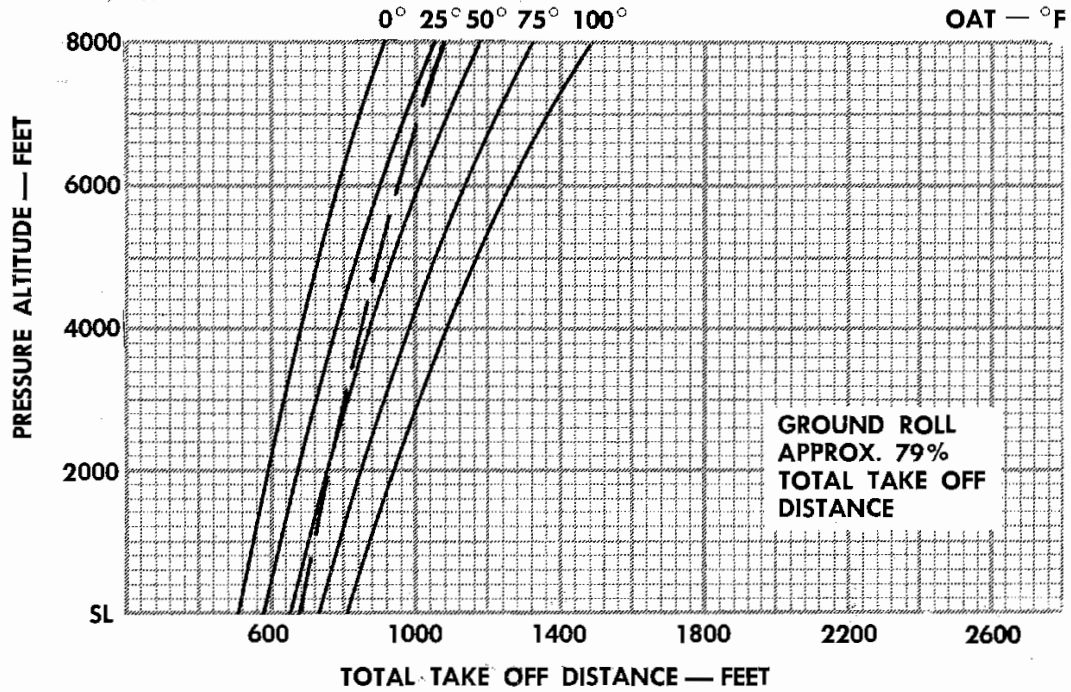

# TWO ENGINE TIME TO CLIMB

GROSS WEIGHT 4200 LBS.

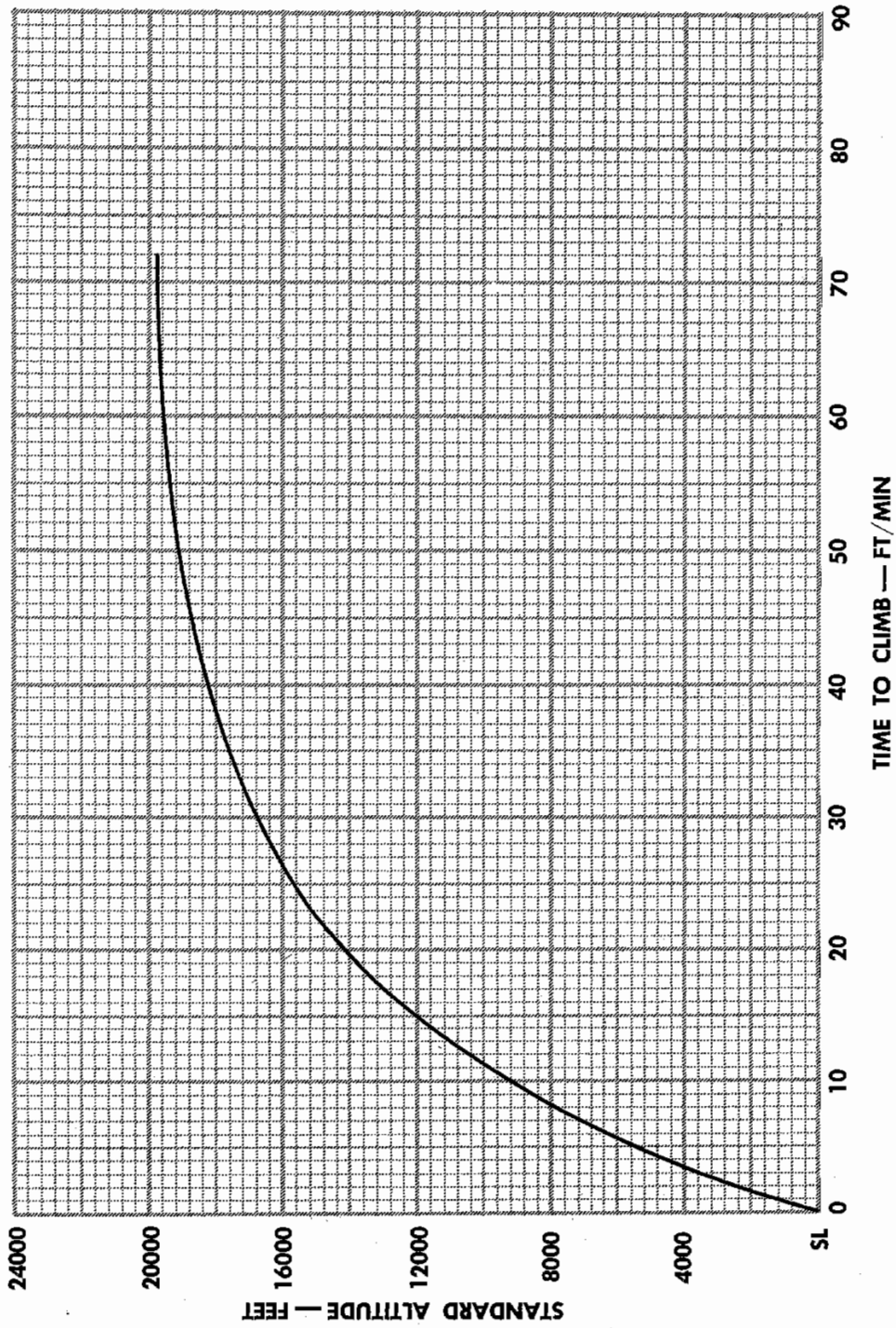



# TWO ENGINE CLIMB PERFORMANCE

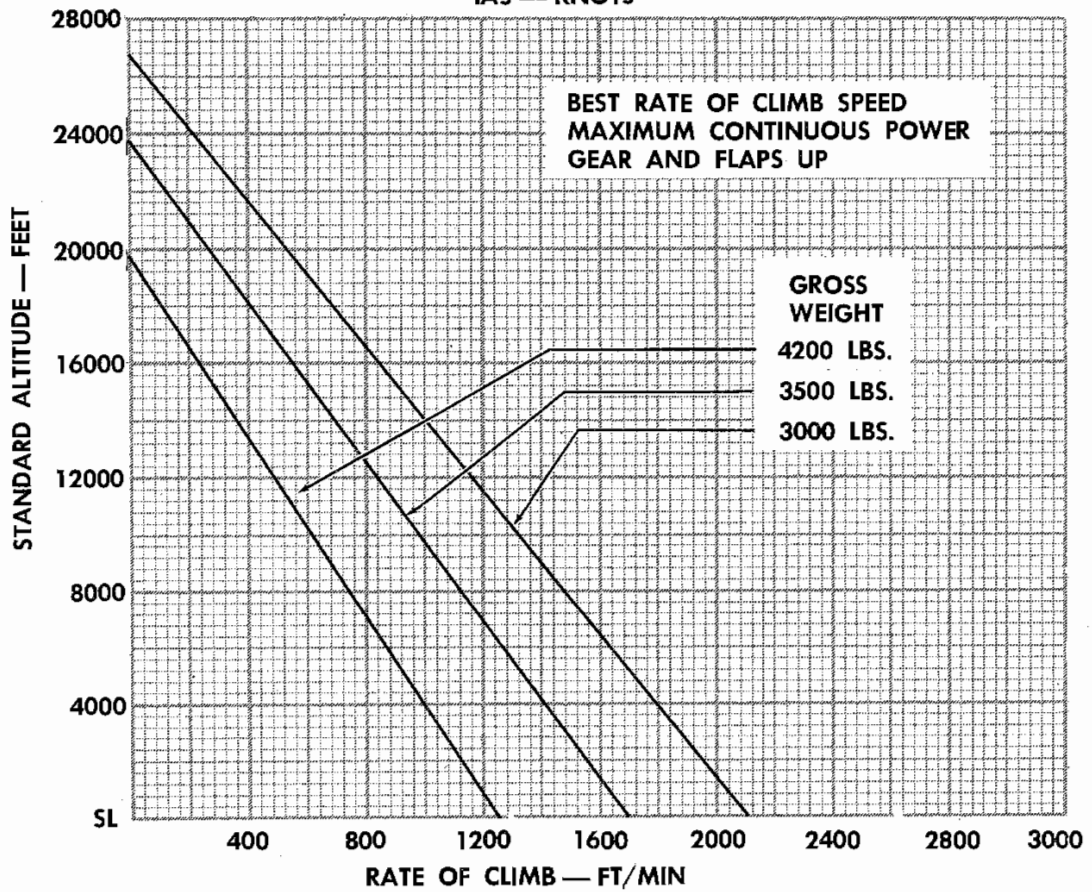
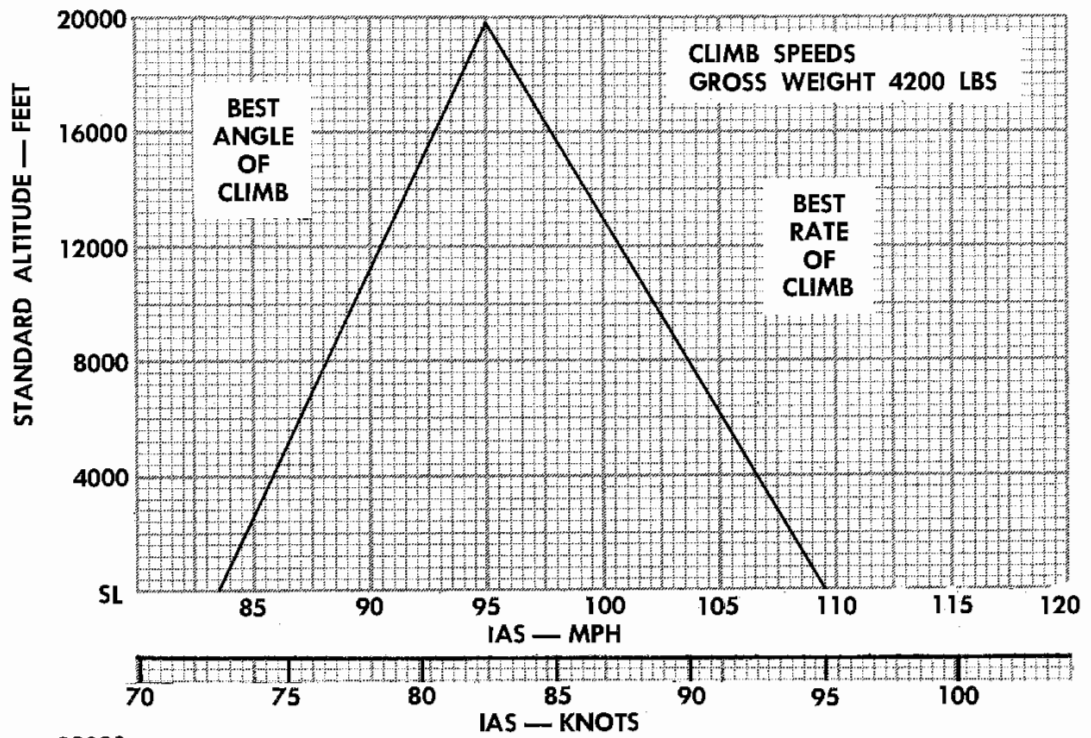

# SINGLE ENGINE CLIMB PERFORMANCE

GROSS WEIGHT 4200 LBS.  
 GEAR AND FLAPS UP  
 MAXIMUM CONTINUOUS POWER  
 INOPERATIVE PROPELLER FEATHERED  
 COWL FLAP FULLY OPEN  
 — — STD TEMP

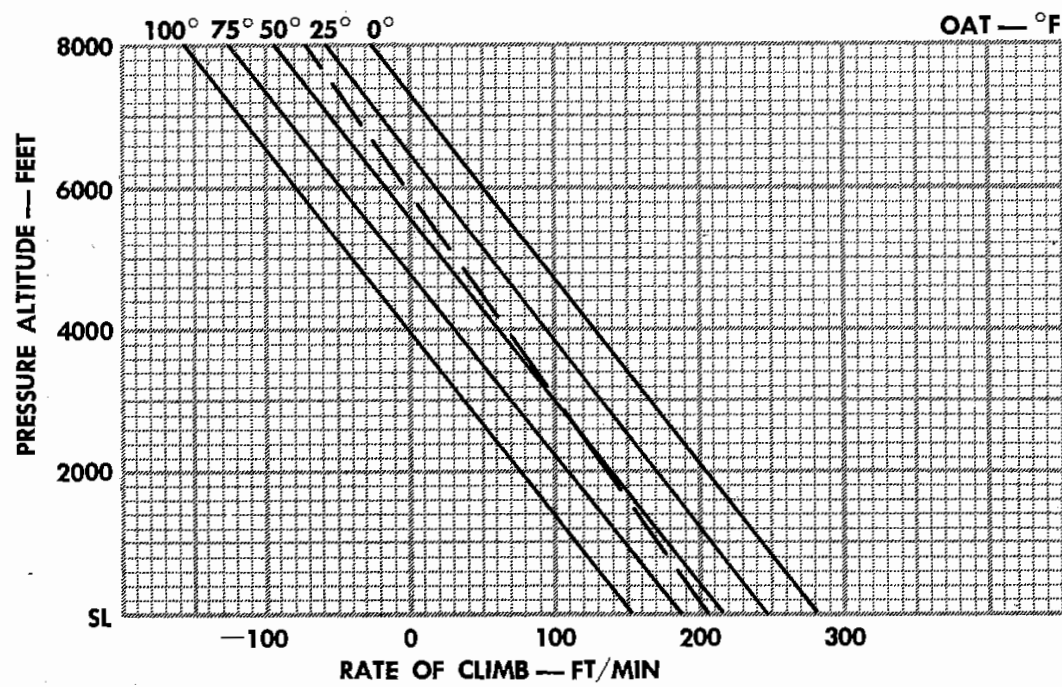
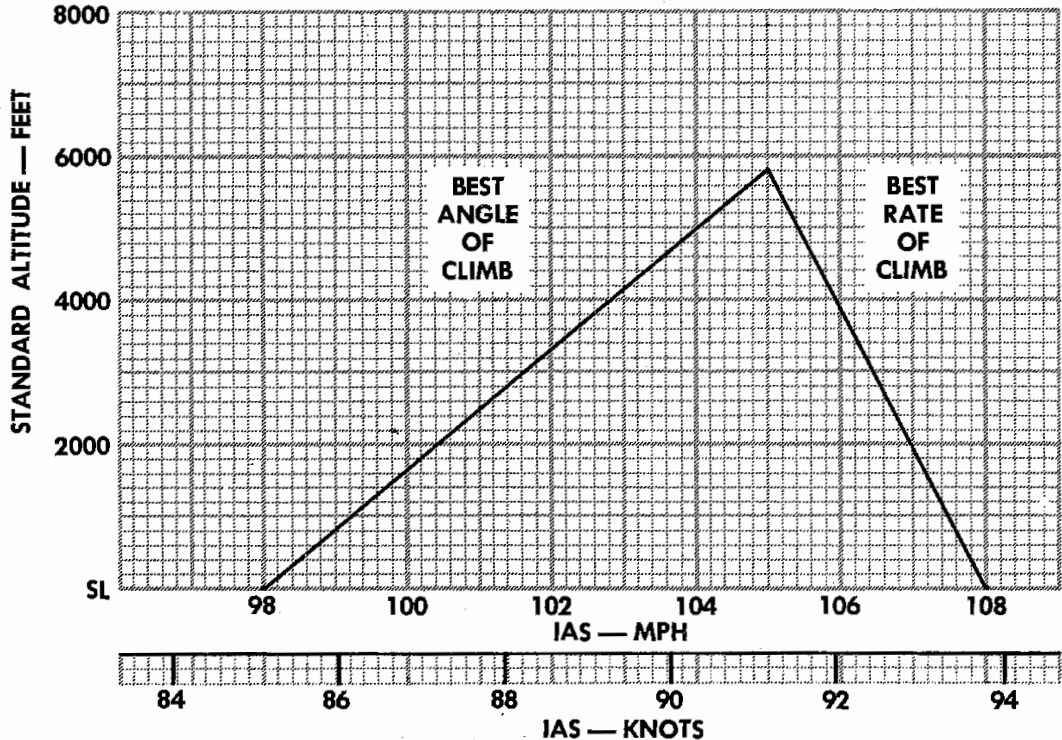

# SINGLE ENGINE EMERGENCY RATE OF CLIMB

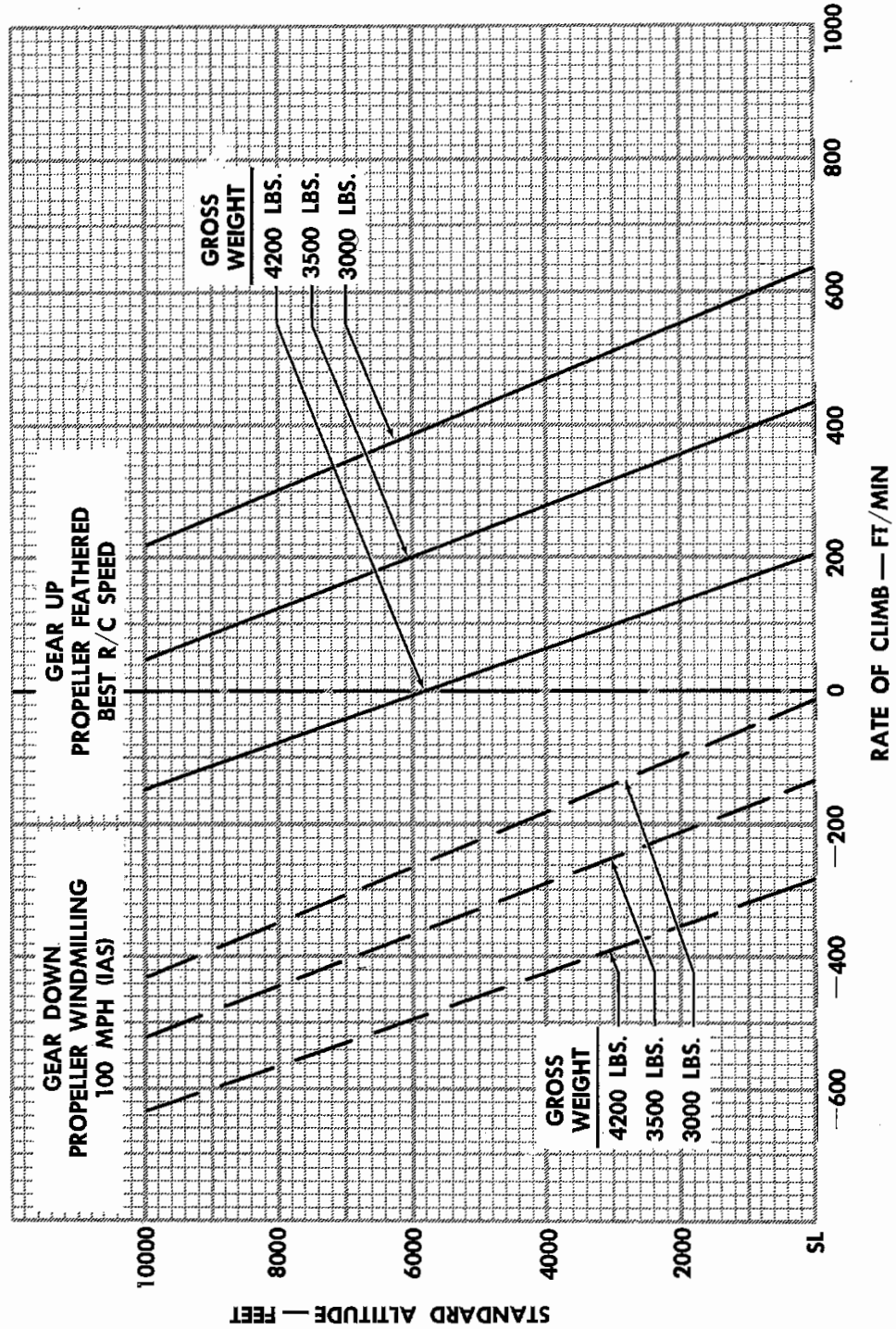

# FUEL CONSUMPTION

GROSS WEIGHT 4200 LBS.

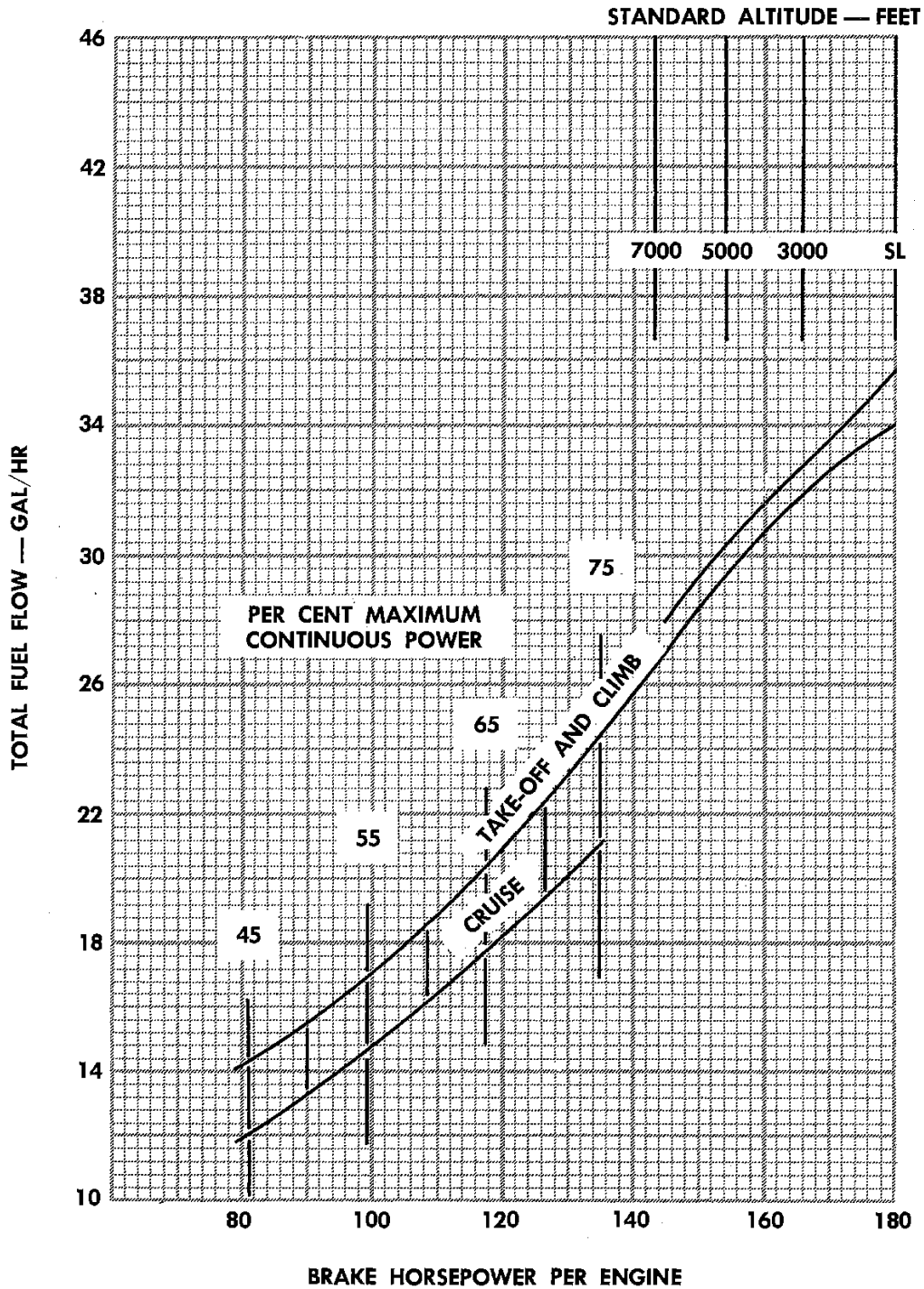

# ALTITUDE CONVERSION

EXAMPLE: IF AMBIENT TEMP. IS 80 °F AND PRESSURE ALT. IS 4000 FEET, THE STANDARD ALT. IS 6000 FEET AND  $1/\sqrt{\sigma}$  IS 1.093

$$TAS = CAS \times 1/\sqrt{\sigma}$$

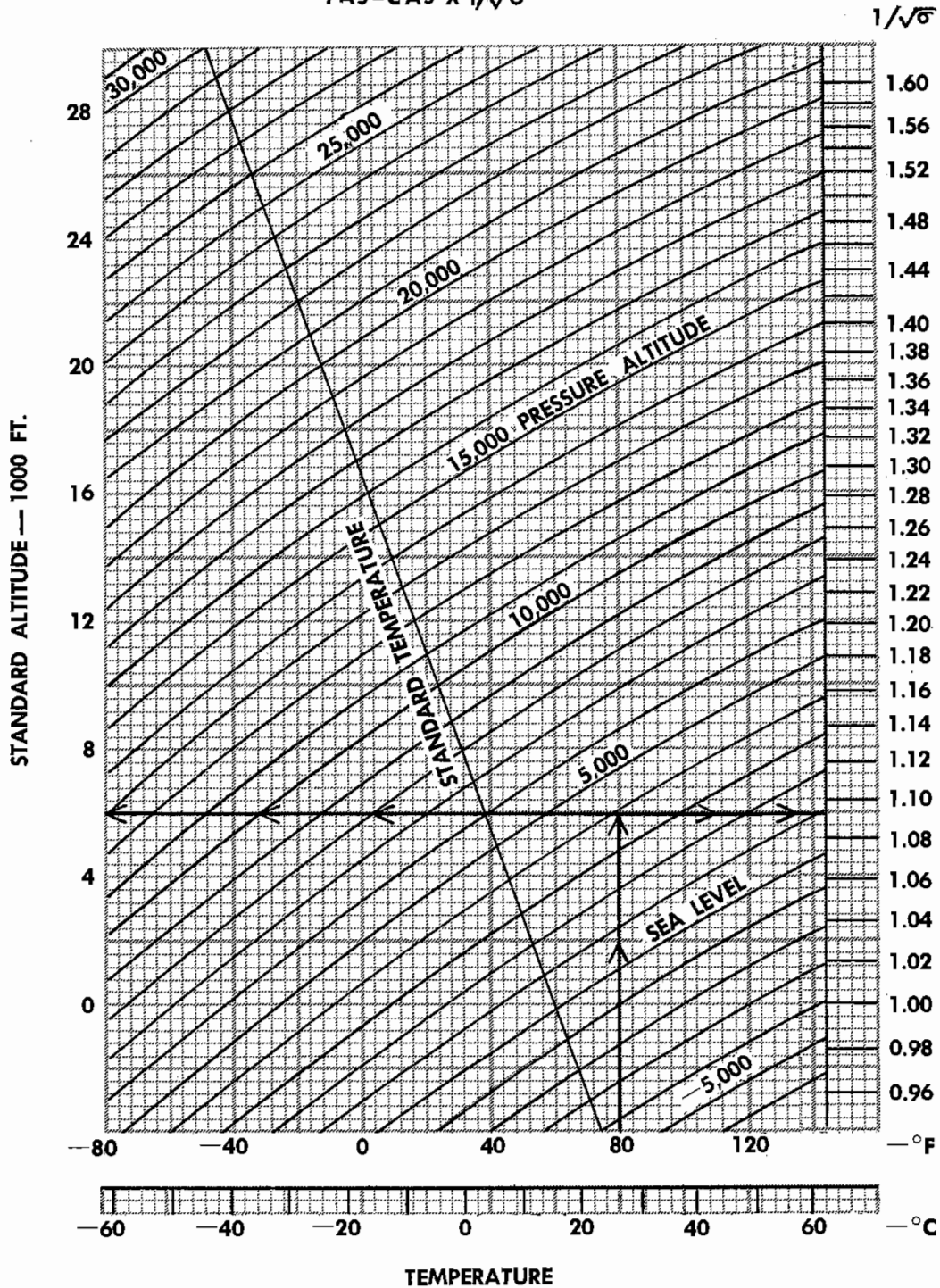

# CRUISING OPERATION

GROSS WEIGHT 4200 LBS.

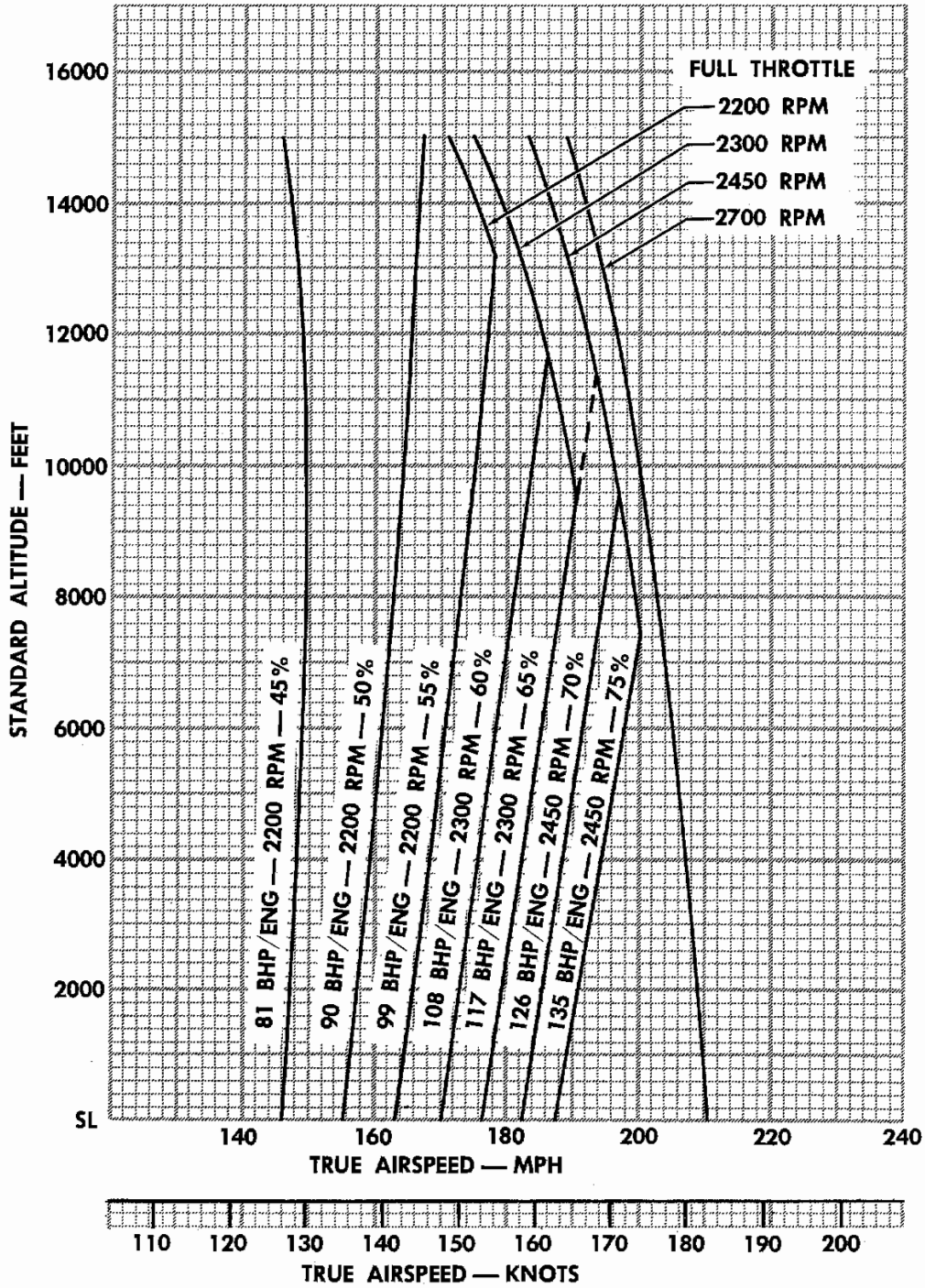

# MANIFOLD PRESSURE VS RPM

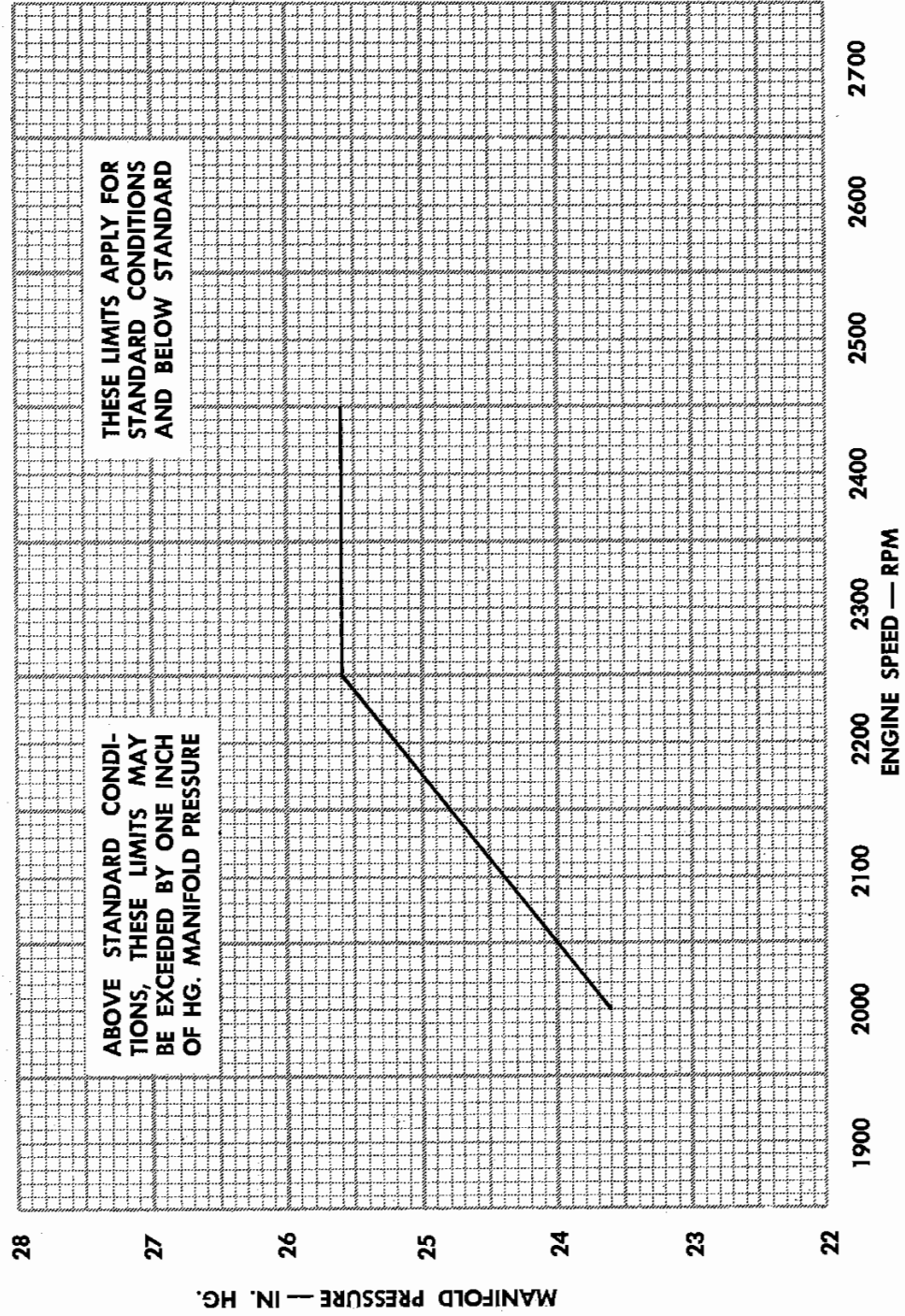

# RANGE

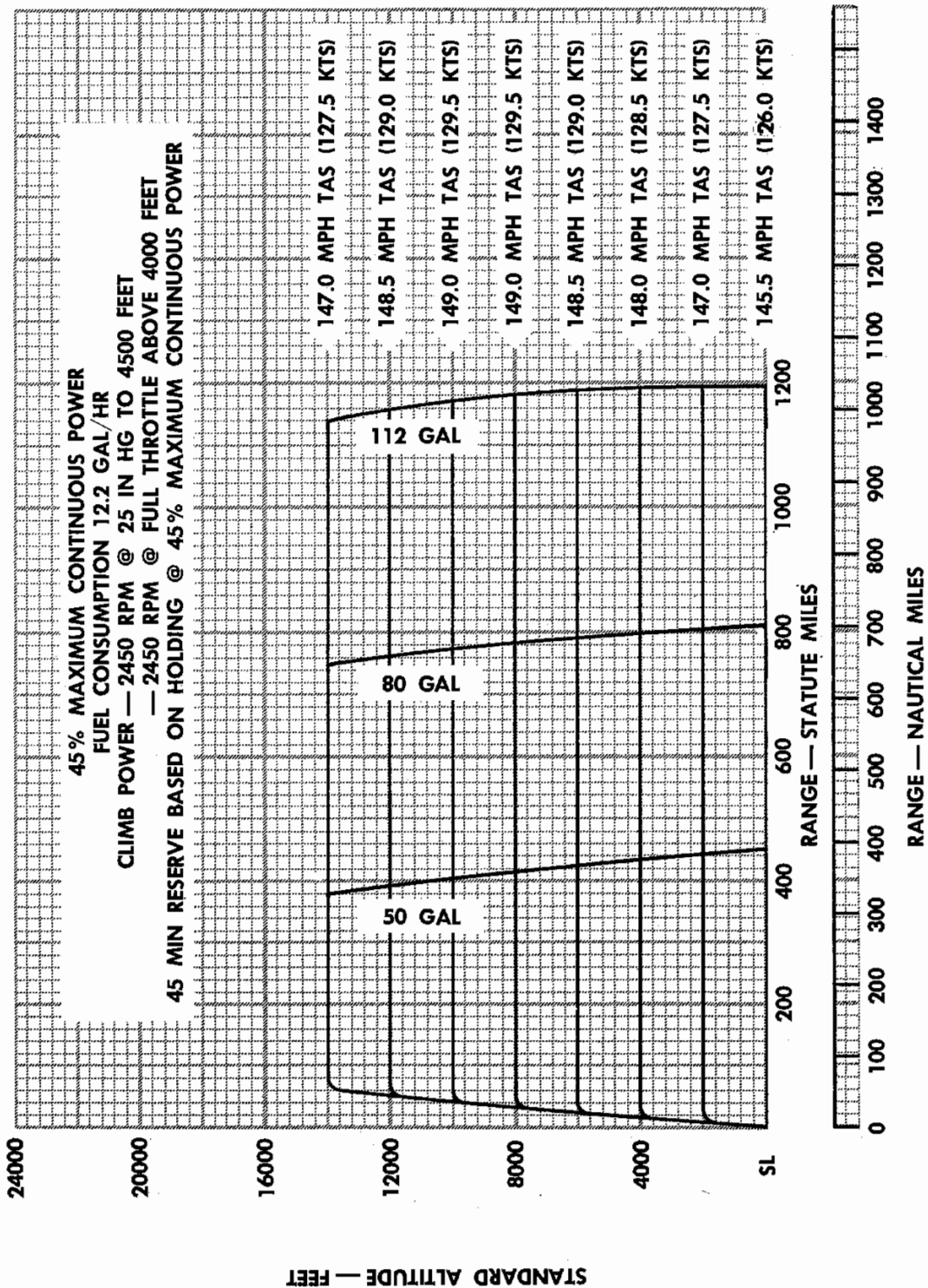



# RANGE

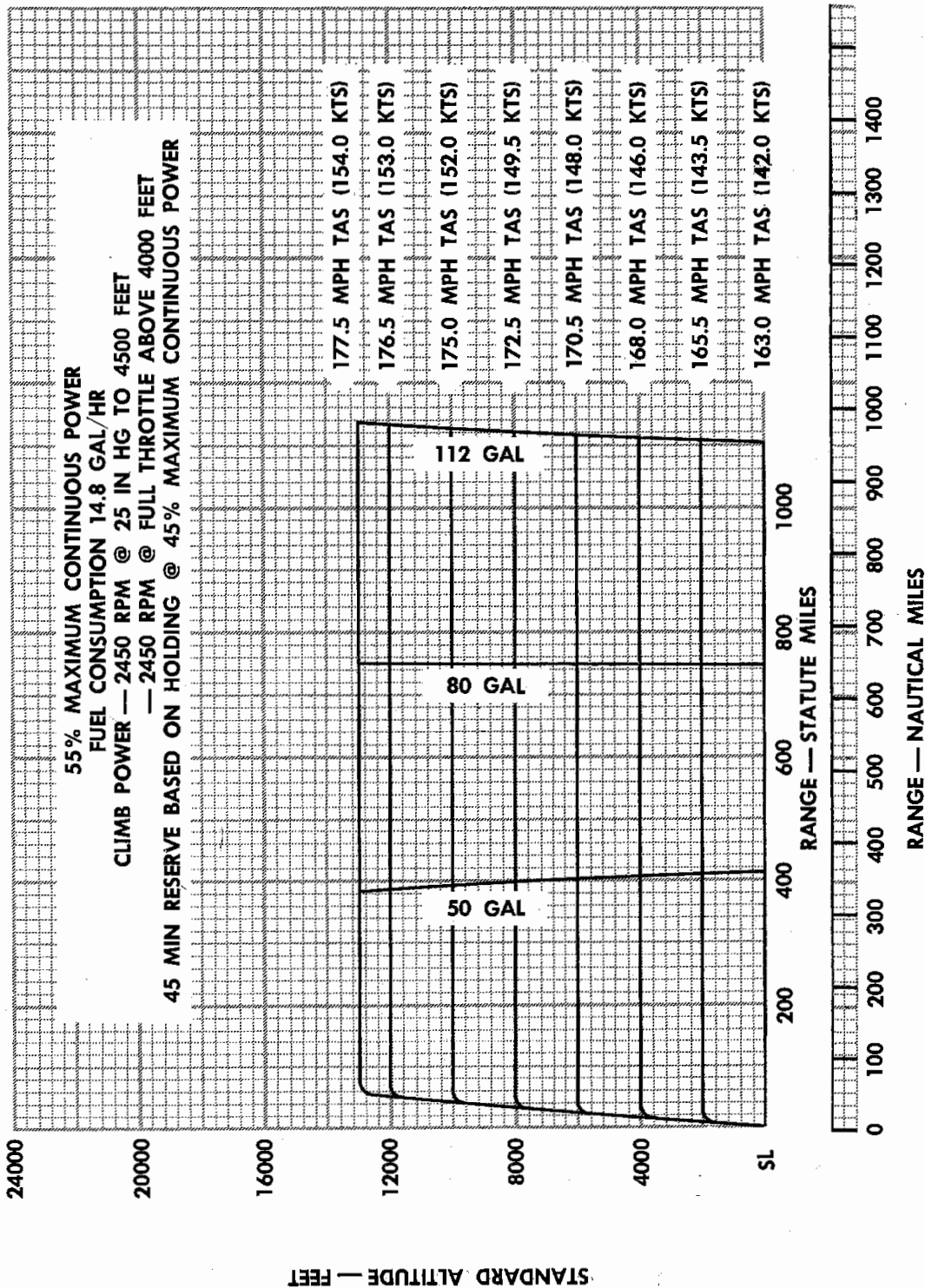

# RANGE

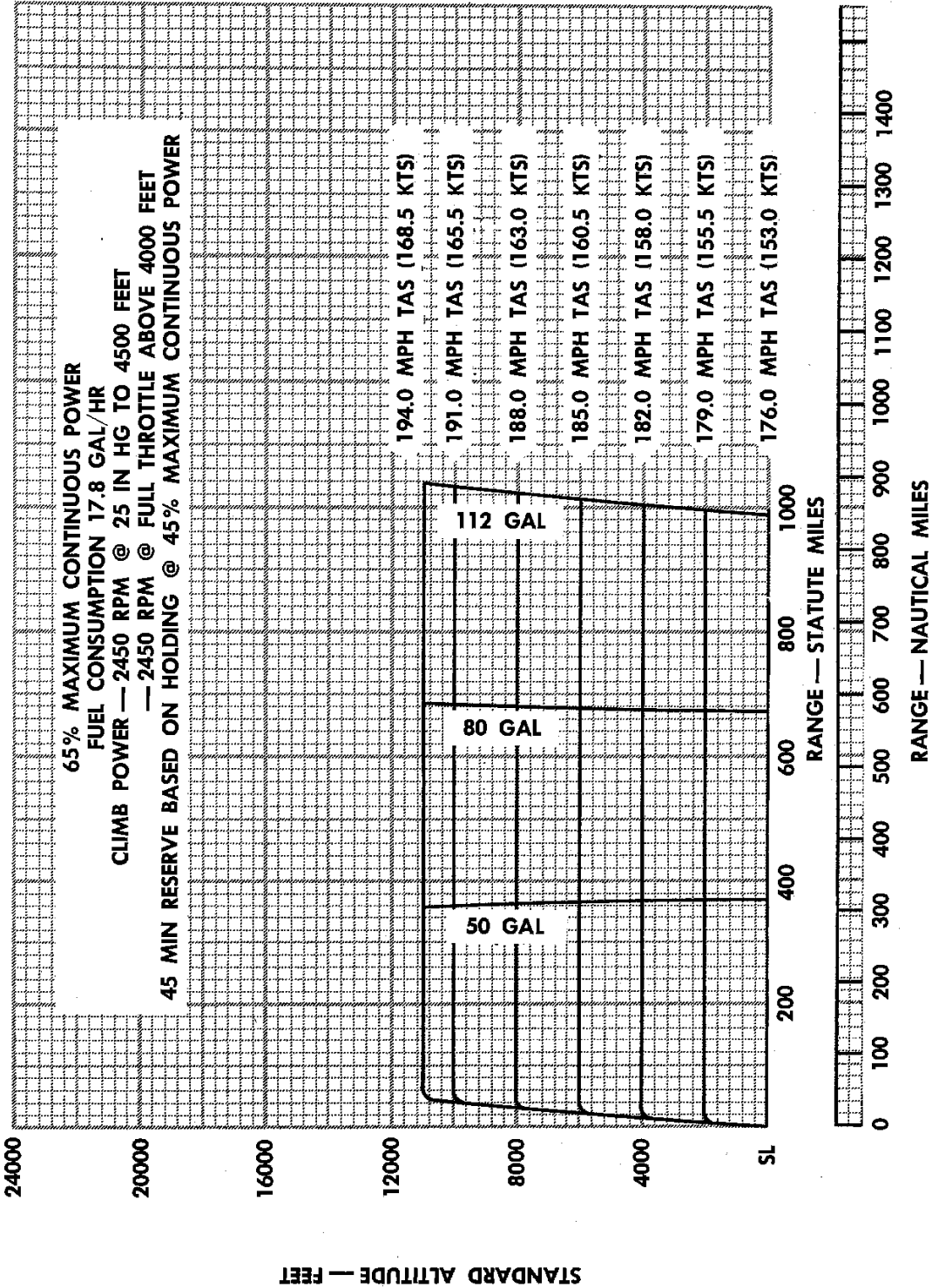

# RANGE

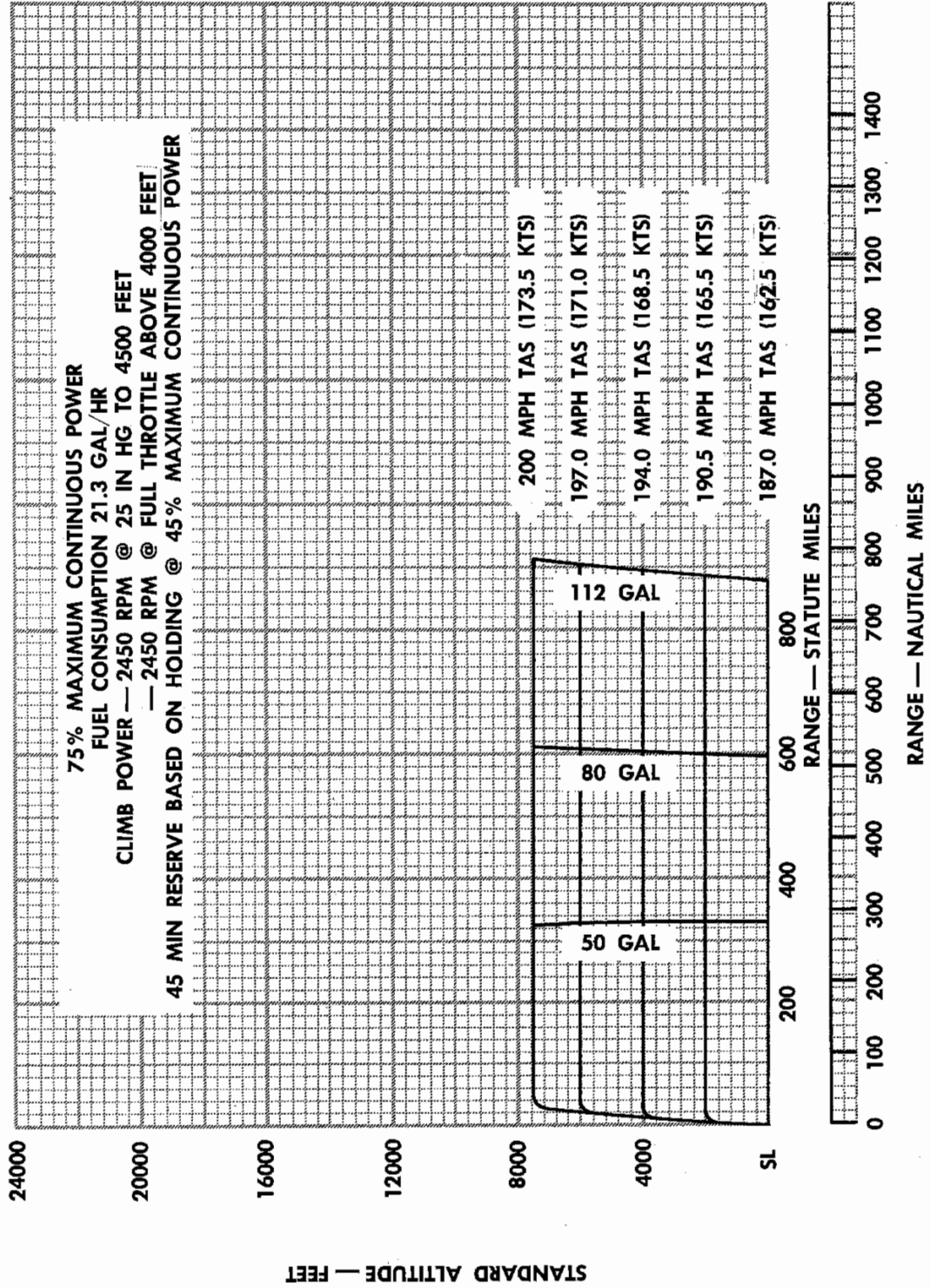

# TURBULENT AIR PENETRATION SPEEDS

GROSS WEIGHT 4200 LBS.

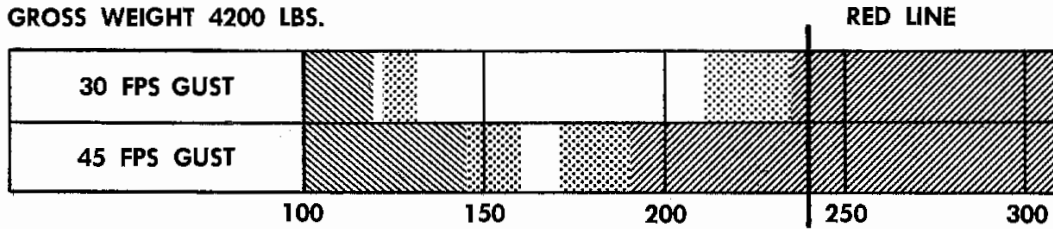

MINIMUM WEIGHT — 2775 LBS.

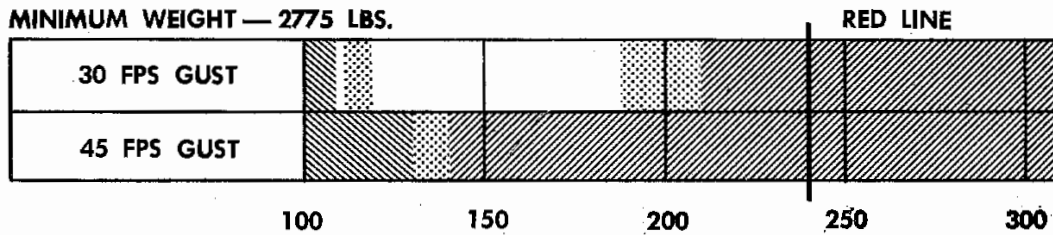

LEGEND

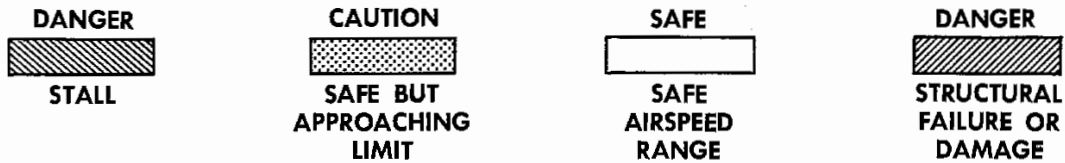

# FLIGHT LOAD FACTORS

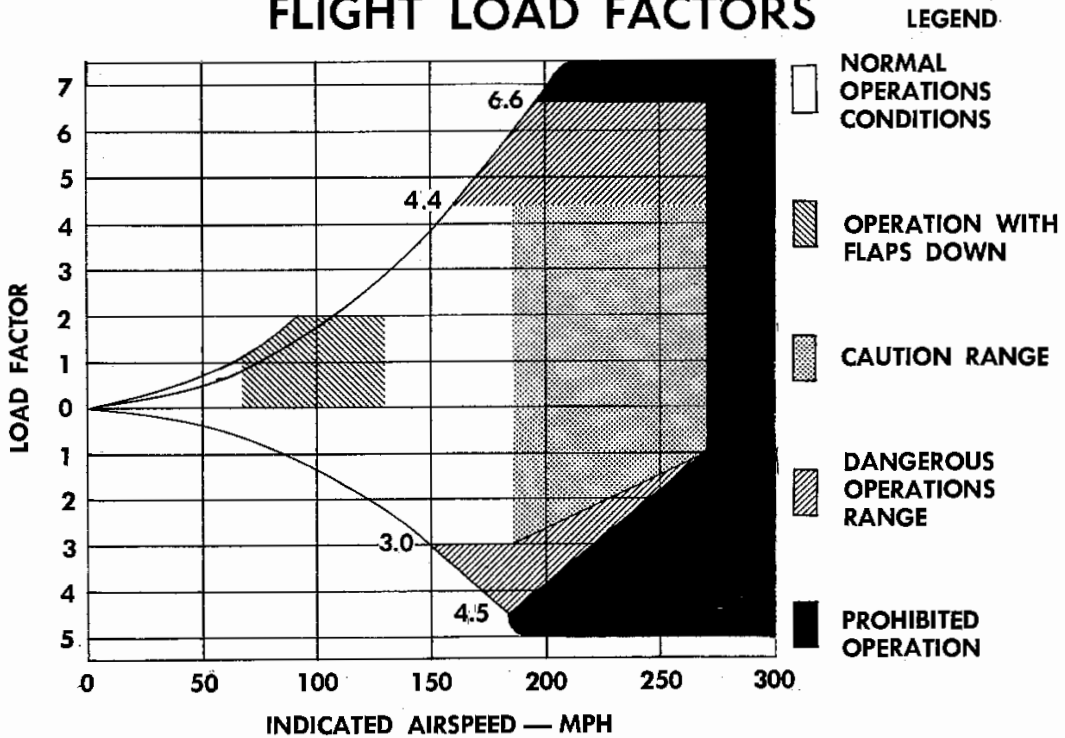

# ACCELERATE AND STOP DISTANCE

GROSS WEIGHT 4200 LBS.  
FLAPS UP

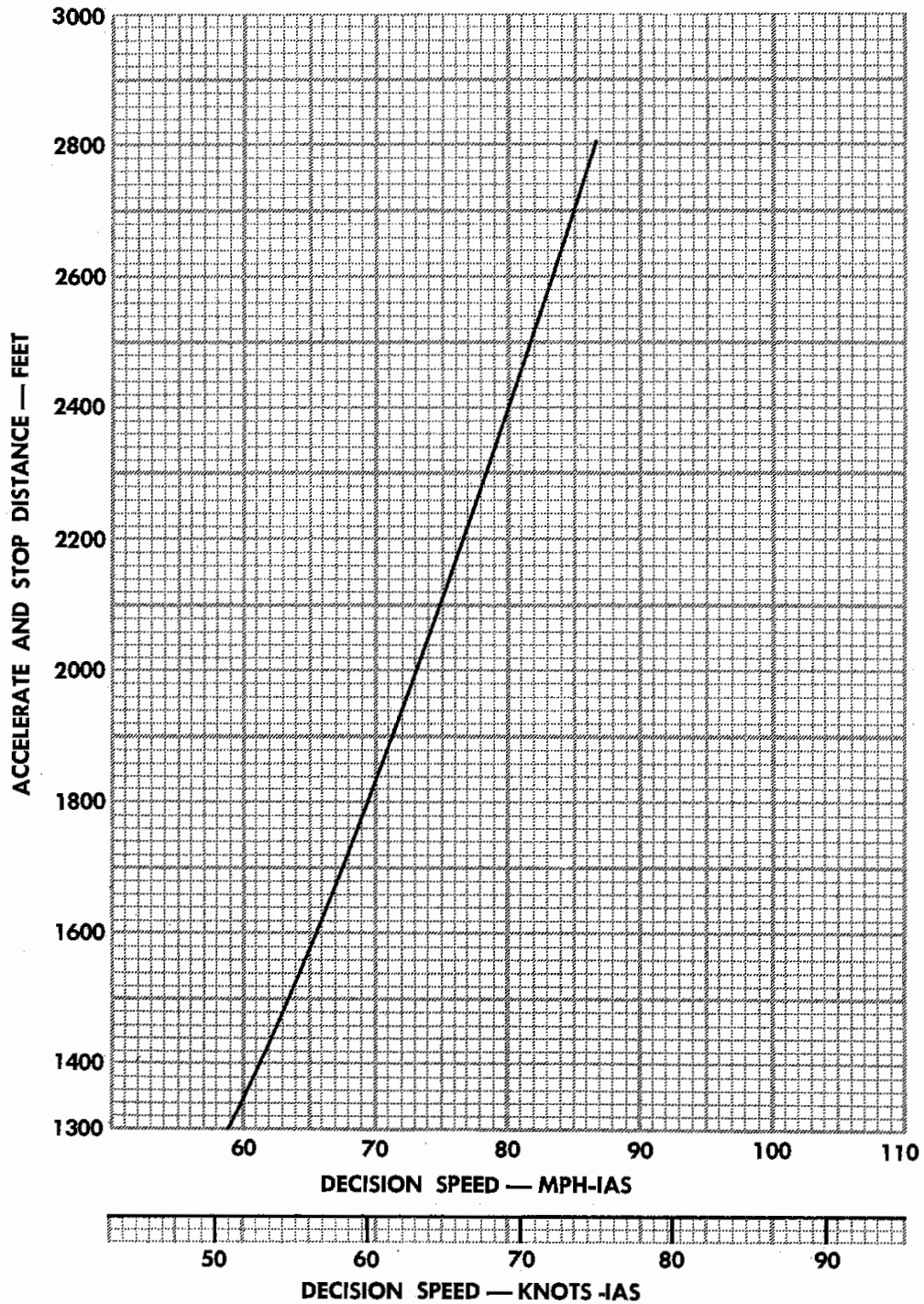

# NORMAL LANDING

DISTANCE OVER 50 FEET  
GROSS WEIGHT 4200 LBS  
FLAPS 28 DEGREES  
APPROACHED SPEED AT 50 FEET = 91 MPH/78.8 KTS (IAS)  
— — STD. TEMP.

NO WIND

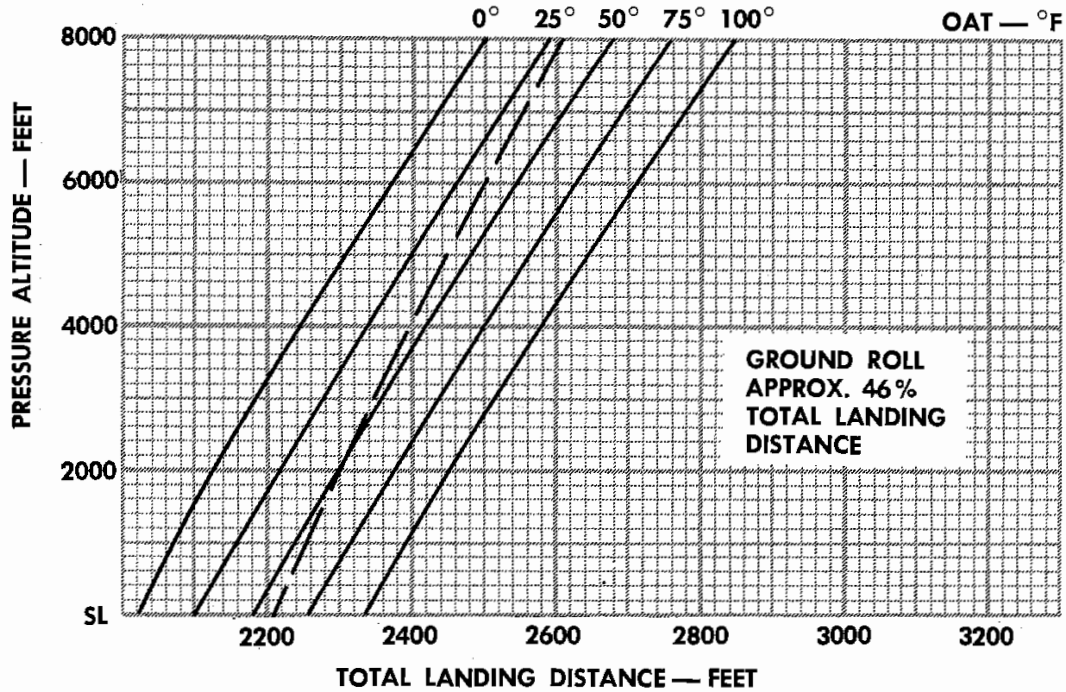

10.0 MPH/8.7 KTS

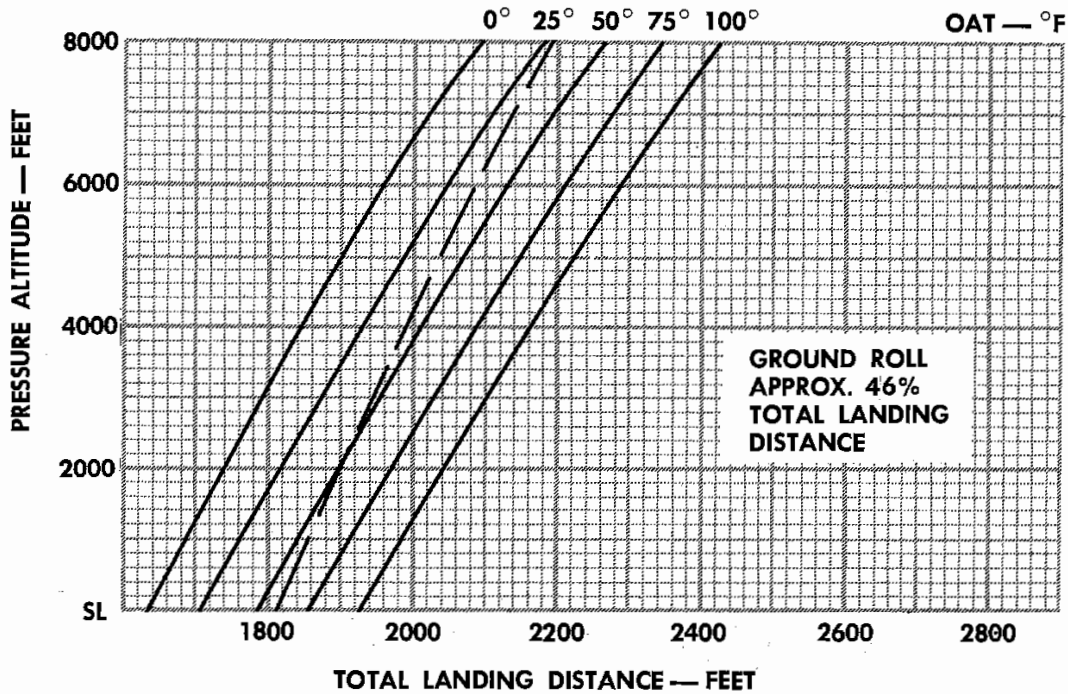

# NORMAL LANDING

DISTANCE OVER 50 FEET  
GROSS WEIGHT 4200 LBS

FLAPS 28 DEGREES

APPROACHED SPEED AT 50 FEET = 91 MPH/78.8 KTS (IAS)

— — STD. TEMP.

20 MPH/17.4 KTS HEADWIND

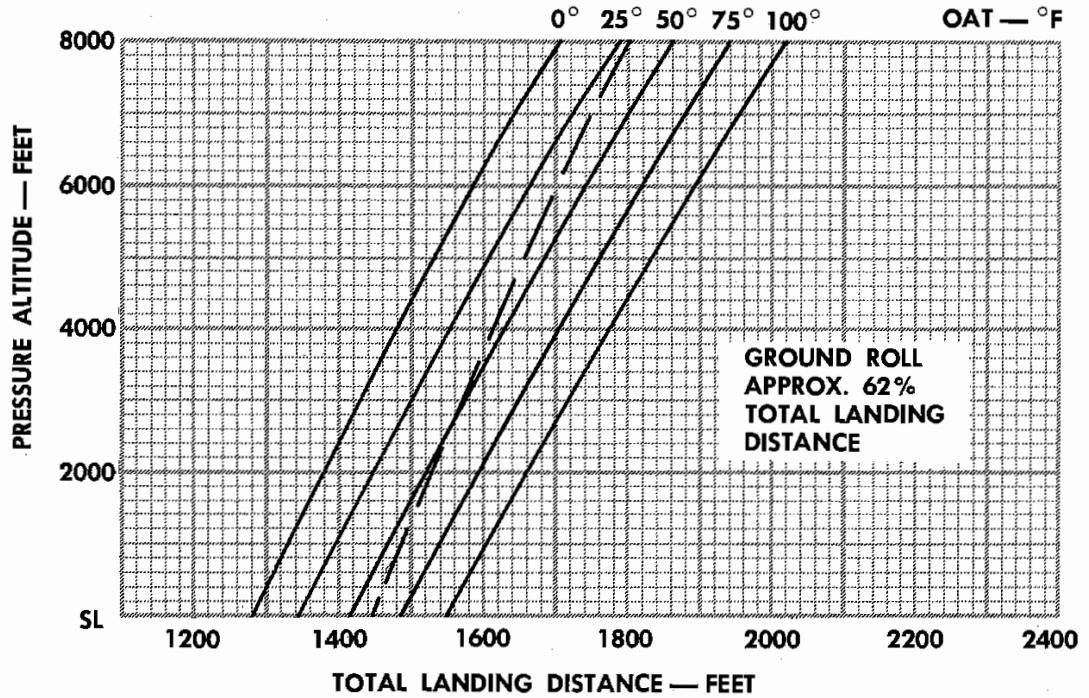

30 MPH/26.1 KTS HEADWIND

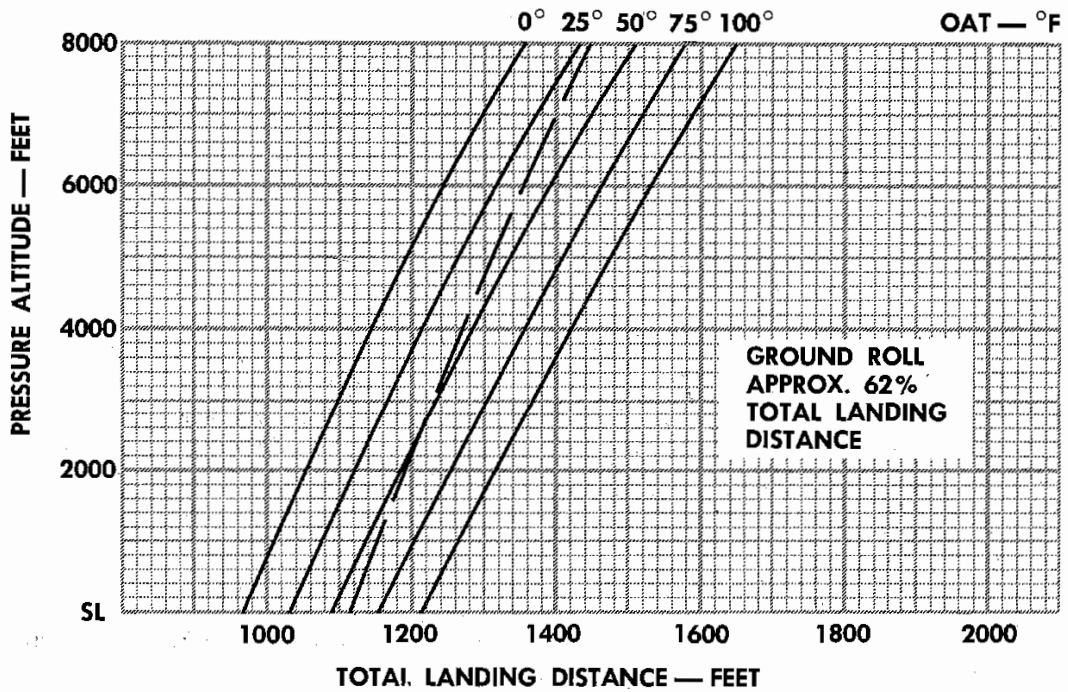

# SHORT FIELD LANDING

DISTANCE OVER 50 FEET  
 GROSS WEIGHT 4200 LBS  
 FLAPS 28 DEGREES  
 APPROACHED SPEED AT 50 FEET = 85 MPH/73.8 KTS (IAS)  
 — — STD. TEMP.

NO WIND

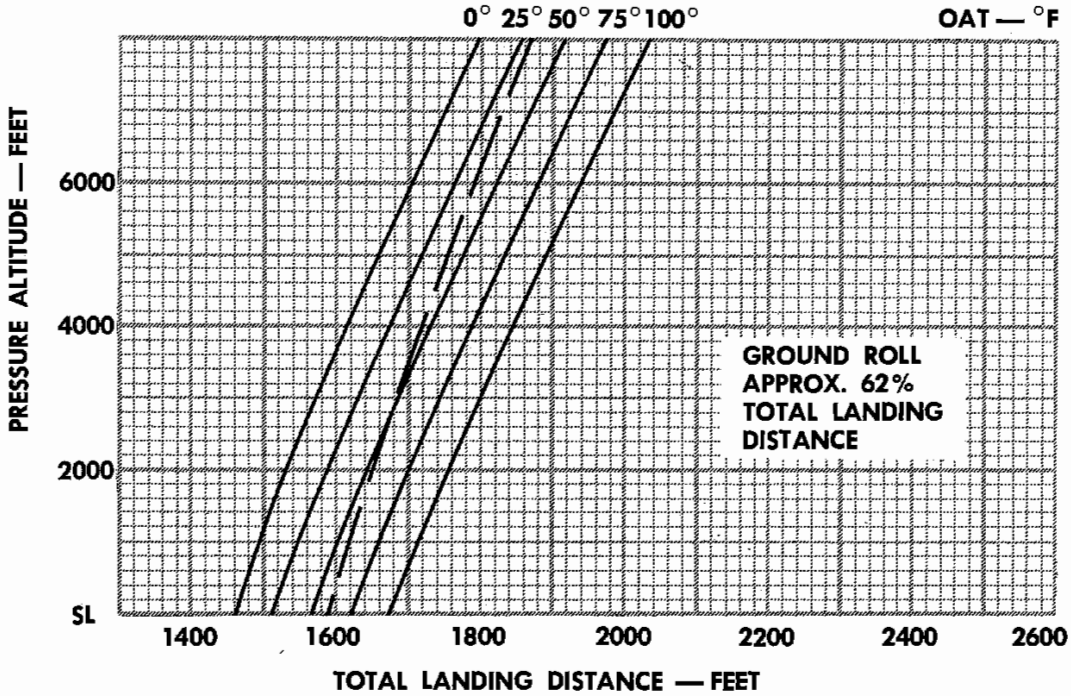

10 MPH/8.7 KTS HEADWIND

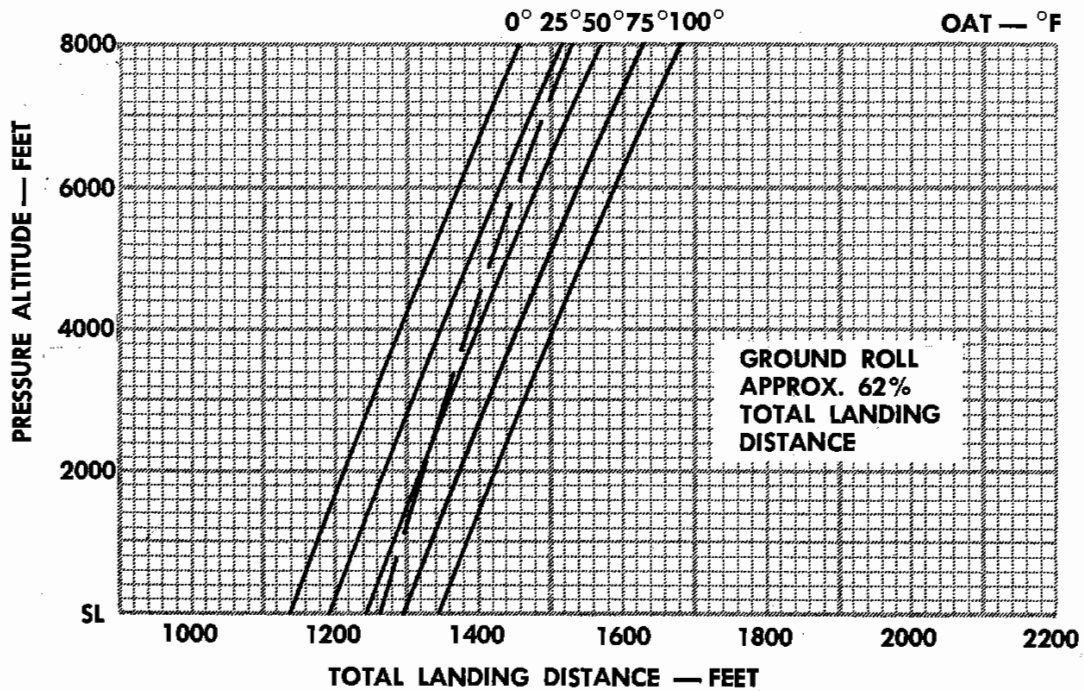



# SHORT FIELD LANDING

DISTANCE OVER 50 FEET  
 GROSS WEIGHT 4200 LBS  
 FLAPS 28 DEGREES  
 APPROACHED SPEED AT 50 FEET = 85 MPH/73.8 KTS (IAS)  
 — — STD. TEMP.

20 MPH/17.4 KTS HEADWIND

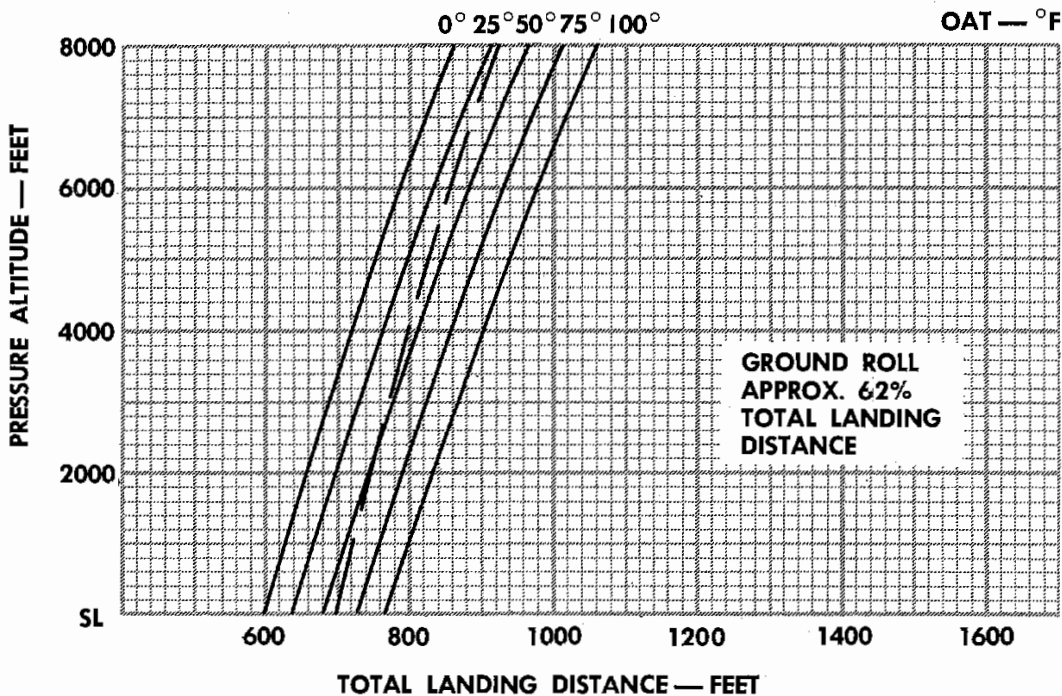
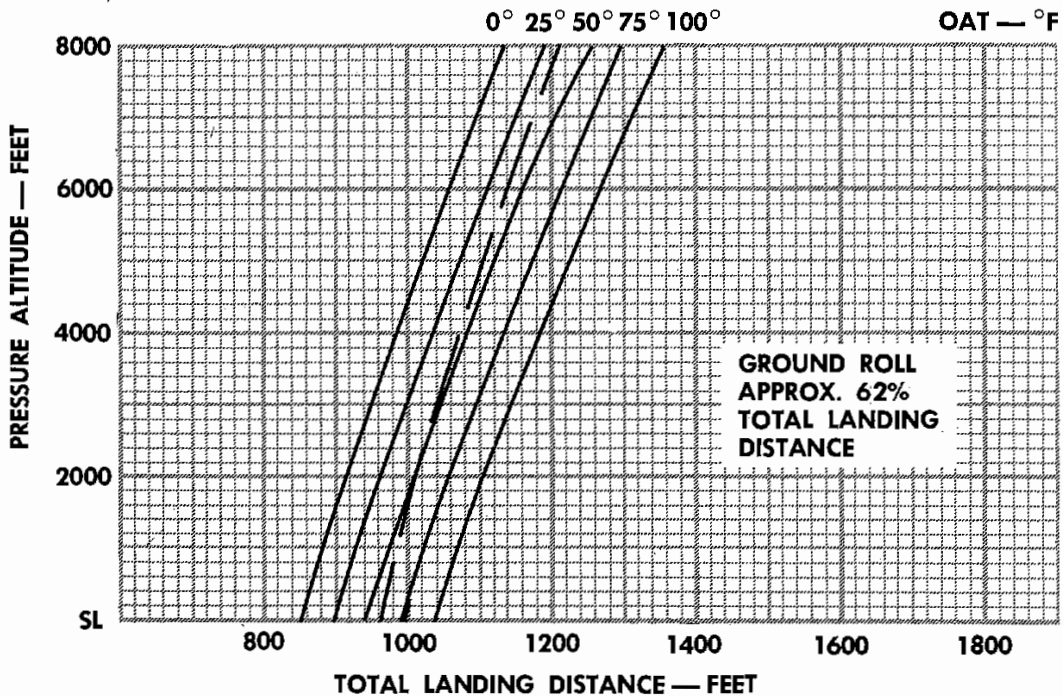

## **SECTION VII**

# ***Servicing and Maintenance***

### **PREVENTIVE MAINTENANCE**

Preventive maintenance is a program designed to keep things from going wrong or not going at all, or quitting before they should reasonably be expected to quit.

Preventive maintenance is in part the responsibility of the airplane's owner or pilot — the best service facility is helpless until the airplane is in the shop with instructions to do the necessary work. The purpose of this section is two fold: first, to provide you with the information necessary for you to decide when the airplane should be sent to a shop, and second, to guide you should you choose, or be obliged by circumstances to do some minor servicing yourself. It is in no sense a substitute for the services of your BEEHCRAFT Certified Service Station. This section includes also information on ground handling, hangar clearances, oil and grease specifications and tire and strut inflation which will be useful on a strange airport.

Carefully followed, the suggestions and recommendations in this section will help keep your Travel Air at peak efficiency throughout its long useful life.

### **BEEHCRAFT CERTIFIED SERVICE**

Aware of our responsibility to our customers to insure that good servicing facilities are available to them, Beech Aircraft Corporation and BEEHCRAFT distributors and dealers have established a world wide network of Certified Service Stations. Service facilities to qualify for certification are required to have available special tools designed to do the best job in the least time on BEEHCRAFT airplanes; to maintain a complete and current file of BEEHCRAFT service publications; and to carry in stock a carefully pre-determined quantity of genuine BEEHCRAFT parts. In addition, key personnel must have

factory training in BEEHCRAFT servicing techniques as well as FAA certificates in power plant, airframe and radio maintenance. A Certified Service Station must be an FAA approved repair station or employ and A and P mechanic with inspection authorization. Certified Service Stations also benefit from frequently scheduled mechanics' training schools held at BEEHCRAFT distributors and from the visits of factory service representatives to the end that their personnel are kept informed of the latest techniques in servicing BEEHCRAFT airplanes.

## **BEEHCRAFT SERVICE PUBLICATIONS**

To bring the latest authoritative information to BEEHCRAFT distributors, dealers and Certified Service Stations and to you as the owner of a BEEHCRAFT airplane, the Parts and Service Operations of Beech Aircraft Corporation publishes and revises as necessary the operating instructions, shop/maintenance manuals and parts catalogs for all BEEHCRAFT airplanes, as well as service bulletins and service letters. All of these publications are available from your BEEHCRAFT distributor or dealer.

## **SERVICE BULLETINS AND SERVICE LETTERS**

BEEHCRAFT service bulletins and service letters are occasional publications dealing with improved operating techniques, revised servicing instructions, special inspections and changes in detailed parts or equipment. Service bulletins and service letters differ mainly in the degree of urgency of their subject matter; service letters usually will announce changes or new equipment which are available for purchase if you choose, or discuss improved operating techniques; service bulletins on the other hand deal with operating techniques, special inspections or changes in the airplane which have a direct bearing on the safety, performance or service life of your Travel Air. Service bulletins carry definite time intervals for compliance, depending on the urgency of their subjects, and you should see that they are complied with before the expiration of the allotted time. One of the services offered by BEEHCRAFT Certified Service Stations is maintaining a record of all service bulletins complied with by them on your airplane.

## **YOUR SERVICE INFORMATION KIT**

In addition to this handbook and the FAA Approved Airplane Flight Manual, the service information kit issued with your Travel Air contains a copy of the official BEECHCRAFT Certified Service Station Directory, an abbreviated check list, engine operator's manual, propeller manual, radio manual, and a horsepower calculator for reference in flight.

## **BEECHCRAFT PARTS AND SERVICE OPERATIONS**

Should a special problem arise concerning your Travel Air, your BEECHCRAFT Certified Service Station, dealer or distributor will supply the information, or if necessary, he will enlist the services of factory personnel through the BEECHCRAFT Parts and Service Operations. His query will be answered by men who are thoroughly familiar with all parts of your Travel Air, and in addition to their own knowledge may call on the engineers who designed it and the expert workmen who built it. Parts and Service Operations maintains service records containing all information received by the factory on all BEECHCRAFT airplanes.

The work of Parts and Service Operations also includes conducting service schools for BEECHCRAFT mechanics and annual Service Clinics at the facilities of various BEECHCRAFT distributors to which you will be invited to bring your Travel Air each year. During the Service Clinic, factory experts will inspect your Travel Air and give you a written report of their findings without obligation to you.

## **GROUND HANDLING**

Knowing how to handle the airplane on the ground is fully as important as knowing how to handle it in the air. In addition to taxiing, parking and mooring, you may find it necessary to maneuver into a hangar by hand or with a tug; or to jack up a wheel. Doing these jobs is not difficult, but if they are done incorrectly, structural damage may result.

So that you may make certain a strange hangar with doubtful clearance is adequate, the three-view drawing on Page *vi* shows the minimum

hangar clearances for a standard airplane. You must, of course, make allowances for any special radio antennae you have installed; their height should be checked and noted on the drawing for future reference.

### **Main Wheel Jacking**

If it becomes necessary to replace a wheel or tire, proceed as follows: Make certain the shock strut is properly inflated to the correct height.

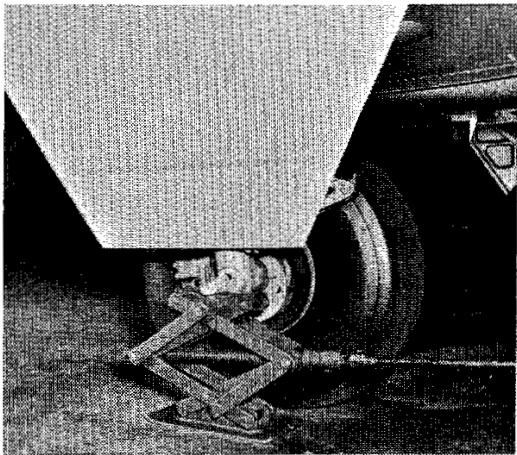

Insert the main wheel jack adapter, furnished with the airplane as part of the loose equipment, into the main wheel axle. If the strut is not inflated to the recommended height, it will be impossible to insert the jack adapter into the main wheel axle. Raise and lower the main wheel as necessary. A scissor-type jack is recommended. When lowering the airplane, care should be taken not to compress

the shock strut, thus forcing the landing gear door against the jack adapter.

### **NOTE**

Do not walk on the wing walk while the airplane is on the main wheel jack.

### **Towing**

To tow the Travel Air, attach the hand towbar to the tow lug on the nose gear lower torque knee. One man can move the aircraft on a smooth and level surface with the towbar.

### **CAUTION**

Do not push on propeller or control surfaces. Do not place your weight on the horizontal stabilizers to raise the nose wheel off the ground. When towing with a tug, observe turn limits to prevent damage to the nose gear.

## **EXTERNAL POWER (Optional Equipment)**

Before connecting an auxiliary power unit, turn off the battery and generator switches and any other electrically operated equipment (if alternators are installed, they also should be turned off). If the auxiliary power unit does not have a standard AN type plug, check the polarity of the unit and connect the positive lead to the center terminal and the negative lead to the remaining large terminal of the aircraft's external power receptacle located on the outboard side of the left nacelle. Since the aircraft has a negative ground system, a negative ground auxiliary power unit is required.

After the engines have been started and the auxiliary power unit disconnected, the electrical system switches may be turned on and normal procedures resumed.

Recharging a battery without removing it from the aircraft may be accomplished by connecting a known negative ground auxiliary power unit to the aircraft's external power receptacle and turning on the battery master switch. In case of an extremely weak battery, removal and pre-charging may be necessary, since the battery may not have sufficient capacity to close the battery solenoid.

### **CAUTION**

If the power unit is not a negative ground, a battery fire may result when the battery master switch is turned on. If external power is used to check radio equipment, make certain that the polarity is correct and that the battery master switch is on, to prevent damage to transistors from voltage transients.

## **ALTERNATOR HANDLING PRECAUTIONS**

Since the alternator and electronic voltage regulator are designed for use on only one polarity system, the following precautionary measures *MUST* be observed when working on the charging circuit. Failure to observe these precautions will result in serious damage to the electrical equipment.

1. When installing a battery, be sure the ground polarity of the battery and the ground polarity of the alternator are the same.
2. When connecting a booster battery, make certain to connect the

negative battery terminals together and the positive battery terminals together.

3. When using a battery charger, connect the positive lead of the charger to the positive battery terminal and the negative lead of the charger to the battery negative terminal.
4. Do not operate an alternator on open circuit. Be sure all circuit connections are secure.
5. Do not short across or ground any of the terminals on the alternator or electronic voltage regulator.
6. Do not attempt to polarize an alternator.

## **SERVICING**

The following service procedures will keep your Travel Air in top condition between visits to your Certified Service Station. These procedures were developed from engineering information, factory practice and the recommendations of engine and parts suppliers, as well as operating experience with thousands of BEEHCRAFT airplanes using identical or similar components. They are the essence of preventive maintenance.

### **Magnetos**

Ordinarily, the magnetos will require only occasional adjustment, lubrication and breaker point replacement, which should be done by your Certified Service Station.

### **CAUTION**

To be safe, treat the magnetos as hot whenever a switch lead is disconnected at any point; they do not have an internal automatic grounding device. The magnetos may be grounded by replacing the switch lead at the noise filter capacitor with a wire which is grounded to the engine case. Otherwise, all spark plug leads should be disconnected or the cable outlet plate on the rear of the magneto should be removed.

### **Servicing the Oil System**

The Travel Air is provided with a wet sump pressure-type oil system.

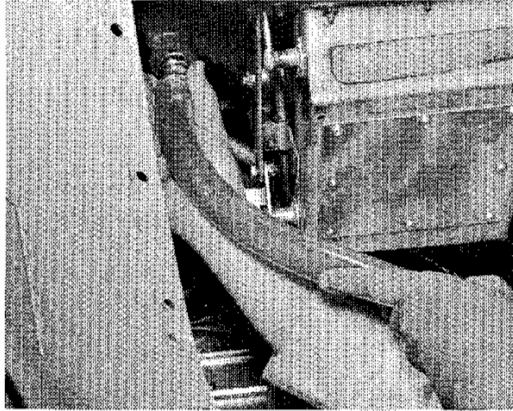

Each engine sump capacity is eight quarts with an absolute minimum capacity of two quarts required for safe engine operation. An access door is provided in the cowling to service the oil system. A calibrated dip stick attached to the filler cap indicates the oil level. The oil should be changed every 50 hours under normal operating conditions. When oper-

ating under adverse weather conditions or continuous high power settings, the oil should be changed more frequently.

#### **NOTE**

The special preservative oil which is in the engines of the Travel Air when the airplane is delivered from the factory, should be changed for normal oil after 25 hours of engine operation.

The oil may be drained by opening the drain valve from the bottom inboard side of the oil sump, the low spot of the system. The engines should be warmed up to operating temperature to assure complete draining of the oil. Moisture that may have condensed and settled in the oil sump should be drained by occasionally opening the drain



valve and allowing a small amount of oil to escape; this is particularly important in winter when moisture will collect more rapidly and freeze.

The oil suction and pressure screens should be cleaned at each periodic oil change. To clean the suction screen, remove the hexhead plug at the rear of the oil sump and pull out the screen. To clean the pressure screen, remove the four bolts that secure the screen housing to the engine accessory section. Pull the housing back and remove the screen. Wash the screens in Stoddard Solvent, Federal Specification P-S-661.

Oil grades listed in the Consumable Materials Chart in the latter portion of this section are recommendations only, and will vary with individual circumstances. The determining factor for choosing the correct grade of oil is the oil inlet temperature observed during flight. Inlet temperatures consistently near the maximum allowable indicate a heavier oil is needed.

Until recently it has been the policy of the engine manufacturer to approve only straight mineral base, aviation grade, nondetergent oil; however, some aviation additive type oils now appear to be superior to straight mineral oil, and their use is recommended. Included with these oils are the multi-viscosity ashless dispersant types. If a change to an additive type oil is elected, the recommendations in the following paragraphs should be observed.

### **CAUTION**

Under no circumstances should such materials as "top cylinder lubricants," "dopes," or "carbon removers" be used. These products may cause damage to the engine, and their presence in an engine will void the owner's warranty. The use of automotive lubricants is also grounds for rejection of any warranty claims.

If an additive oil is used in a new or recently overhauled engine, high oil consumption may possibly be experienced. The anti-friction additives of some of these oils will retard break-in of the piston rings and cylinder walls. This condition may be corrected by using straight mineral oil until normal oil consumption is obtained.

When an engine has been operating on straight mineral oil for more than 100 hours, a change to detergent oil should be made with caution, since the cleaning action of a detergent oil will tend to loosen sludge deposits and cause plugged oil passages. In fact, if any engine that has been operating on straight mineral oil is known to be excessively dirty, the change to detergent oil should be deferred until after overhaul.

When a change is made from straight mineral oil to detergent oil, the oils should not be mixed. After five operating hours the crankcase should be drained and the oil suction and pressure screens checked for evidence of sludge or plugging. If the screens show signs of plugging, the oil should be changed after each ten operating hours until sludge conditions improve, after which normal oil drain periods may be resumed.

### **Servicing the Fuel System**

Service the system with fuels as recommended in the Consumable Materials Chart. A 40-gallon main fuel cell is installed in the inboard portion of each wing leading edge. The optional fuel system installation consists of a 25-gallon main fuel cell in each wing leading edge and a 31-gallon auxiliary cell just aft and outboard of the main cell. Fill each cell separately through the filler neck by removing the flush filler caps from the upper skins.

Open each of the snap type fuel drains daily to allow contaminated fuel to drain from the system. The sump drains extend through the bottom of the wing skins; two drains are located at the system low spots to drain the interconnecting lines and extend through the bottom of the fuselage center section skin; the fuel strainers, which are provided with drains, are located in the wheel wells.

Most fuel injection system malfunctions can be attributed to contaminated fuel. The fuel strainer in each wheel well should be inspected and cleaned after each 100 hours of operation. More frequent inspection and cleaning may be necessary, depending upon service conditions, fuel handling cleanliness, and local sand and dust conditions. The injector fuel inlet strainer should be removed and cleaned after the first 25 hours of operation, then after each 50 operating hours. Dam-

aged strainer "O" rings should be replaced. After reinstallation, a check should be made for leakage. Future fuel system maintenance may be minimized by placing caps over fuel hoses and fittings during maintenance operations.

### **CAUTION**

Never leave the fuel cells completely empty or the cell inner liners may dry out and crack, permitting fuel to diffuse through the walls of the cell after refueling. If cell is to be left empty for a week or more, spray inner liner with a light coat of engine oil.

### **Servicing the Landing Gear**

The shock struts are filled with dry compressed air and hydraulic fluid (see Consumable Materials Chart). When the struts are properly inflated, 3 inches of the piston will be exposed on the main strut and 3½ inches of the piston will be visible on the nose strut. The inflation check should be made with the airplane empty except for full fuel and oil.

The following procedure may be used for servicing both the main and nose gear shock struts.

1. Remove the air valve cap and depress the valve core to release the air pressure.

### **WARNING**

Do not unscrew the air valve assembly until all air pressure has been released or it may blow off, causing injury to personnel or damage to equipment.

2. With the weight of the airplane on the gear, slowly loosen the valve body assembly until all air has escaped, then remove the valve body assembly.
3. Extend the strut ¼ inch from the fully deflated position.
4. Fill the strut to the level of the valve body assembly with hydraulic fluid.
5. Slowly extend the strut an additional ½ inch and replace the valve body assembly.

6. Depress the valve core and completely compress the strut to release excess air and oil.
7. While rocking the airplane gently to prevent possible binding of the piston in the barrel, inflate the shock strut until 3 inches of the piston is exposed ( $3\frac{1}{2}$  inches on the nose strut).

### **CAUTION**

If a compressed air bottle containing air under extremely high pressure is used, care should be exercised to avoid over-inflating the strut.

Since it is essential to long service life that the shock strut pistons be clean and free from foreign material that might score their surfaces, the pistons should be cleaned with a soft cloth containing hydraulic fluid whenever they are dirty or show evidence of grit.

### **Servicing the Brakes**

The ring-disc hydraulic brakes require no adjustments, since the pistons move to compensate for lining wear. A clearance of  $\frac{1}{32}$  inch or less between the brake housing and the torque flange indicates the need for lining replacement. Anvil lining worn to a thickness of  $\frac{5}{32}$  inch, as measured from the rubbing surface to the back of the lining center, should be replaced. Piston lining should be replaced when worn to a thickness of  $\frac{15}{16}$  inch, as measured from the rubbing surface to the bottom of the metal support at the center.

Discs should be checked for small nicks or sharp edges which could damage the brake linings. Worn, dished or distorted brake discs, should be replaced. The fluid reservoir, accessible through the forward baggage compartment, should be checked regularly and a visible fluid level maintained on the dip stick at all times. Refer to the Consumable Materials Chart for hydraulic fluid specification.

### **Servicing the Tires (Tubeless and Tube-type)**

Your Travel Air can be equipped with either tubeless, or tube-type tires on the main and nose landing gear wheels. The tubeless type tire installa-

# SERVICING POINTS

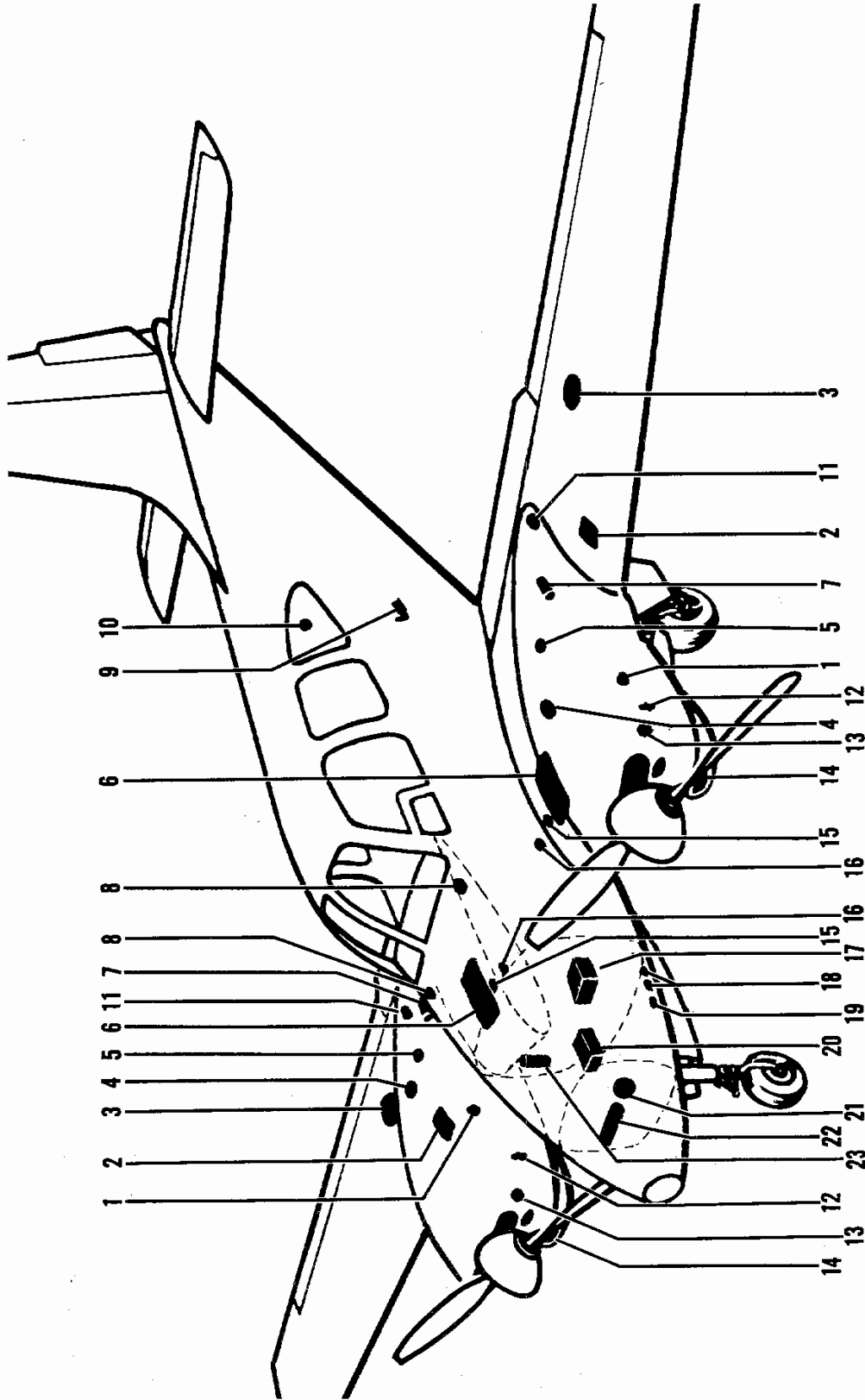

Note: Numbers refer to items in the Service Schedule.

## SERVICE SCHEDULE

ITEM	*LOCATION	PRE-FLIGHT	EVERY 25 HRS.	EVERY 50 HRS.	EVERY 100 HRS.	EVERY 300 HRS.	AS REQ.
DRAIN MAIN FUEL CELL DRAINS	15	X					
DRAIN AUXILIARY FUEL CELL DRAINS	11	X					
DRAIN FUEL STRAINER DRAINS	1	X					
DRAIN FUEL SYSTEM LOW SPOT DRAINS	16	X					
DRAIN HEATER FUEL FILTER	19	X					
CHECK ENGINE OIL LEVEL	4	X					
SERVICE MAIN FUEL CELLS	2 OR 6						X
SERVICE AUXILIARY FUEL CELLS**	3						X
SERVICE PROPELLER ANTI-ICER RESERVOIR**	17						X
SERVICE DEICER RESERVOIR**	21						X
SERVICE OXYGEN RESERVOIR**	10 OR 22						X
SERVICE BRAKE FLUID RESERVOIR	23						X
CLEAN FUEL STRAINERS IN WHEEL WELLS	1				X		
CLEAN FUEL INJECTOR FUEL INLET STRAINER	13			X			
CLEAN HEATER FUEL PUMP STRAINERS	18				X		
CLEAN HEATER FUEL FILTER	19				X		
CHANGE ENGINE OIL	12			X			
CLEAN ENGINE OIL SUCTION SCREEN	5			X			
CLEAN ENGINE OIL PRESSURE SCREEN	7			X			
CLEAN ENGINE INDUCTION AIR FILTER	14			X			
LUBRICATE MAGNETO BREAKER POINTS	L						X
CLEAN AND CHECK SPARK PLUGS	--				X		
CHECK MAGNETO TIMING	--				X		

ITEM	*LOCATION	PRE-FLIGHT	EVERY 25 HRS.	EVERY 50 HRS.	EVERY 100 HRS.	EVERY 300 HRS.	AS REQ.
SERVICE MAIN GEAR STRUTS	J						X
SERVICE NOSE GEAR STRUT	B						X
SERVICE SHIMMY DAMPENER	B						X
LUBRICATE LANDING GEAR MOTOR REDUCTION GEARS	M					X	
SERVICE LANDING GEAR ACTUATOR GEAR BOX	F					X	
LUBRICATE LANDING GEAR DOOR HINGES	G, O				X		
LUBRICATE LANDING GEAR UP LOCK ROLLERS	J			X			
LUBRICATE NOSE WHEEL STEERING MECHANISM	C				X		
LUBRICATE LANDING GEAR RETRACT MECHANISM	B, J				X		
LUBRICATE WHEEL BEARINGS	B, J				X		
CHECK BRAKE LINING WEAR	—						X
CHECK BATTERY ELECTROLYTE LEVEL	20		X				
LUBRICATE HEATER IRIS VALVE	A						X
LUBRICATE CABIN DOOR MECHANISM	E				X		
LUBRICATE AILERON BELL CRANKS	H				X		
LUBRICATE CONTROL COLUMN LINKAGE	D				X		
LUBRICATE FLAP ACTUATORS	I					X	
LUBRICATE FLAP MOTOR REDUCTION GEARS	K					X	
LUBRICATE RUDDER PEDALS	N				X		
REPLACE GYRO INSTRUMENT FILTERS	—				X		
DRAIN STATIC AIR LINES	9				X		
CLEAN VACUUM REGULATOR VALVE SCREENS	8				X		

\*Numbers refer to the servicing points diagram; letters refer to the lubrication points diagram.

\*\*Optional equipment.

# LUBRICATION POINTS

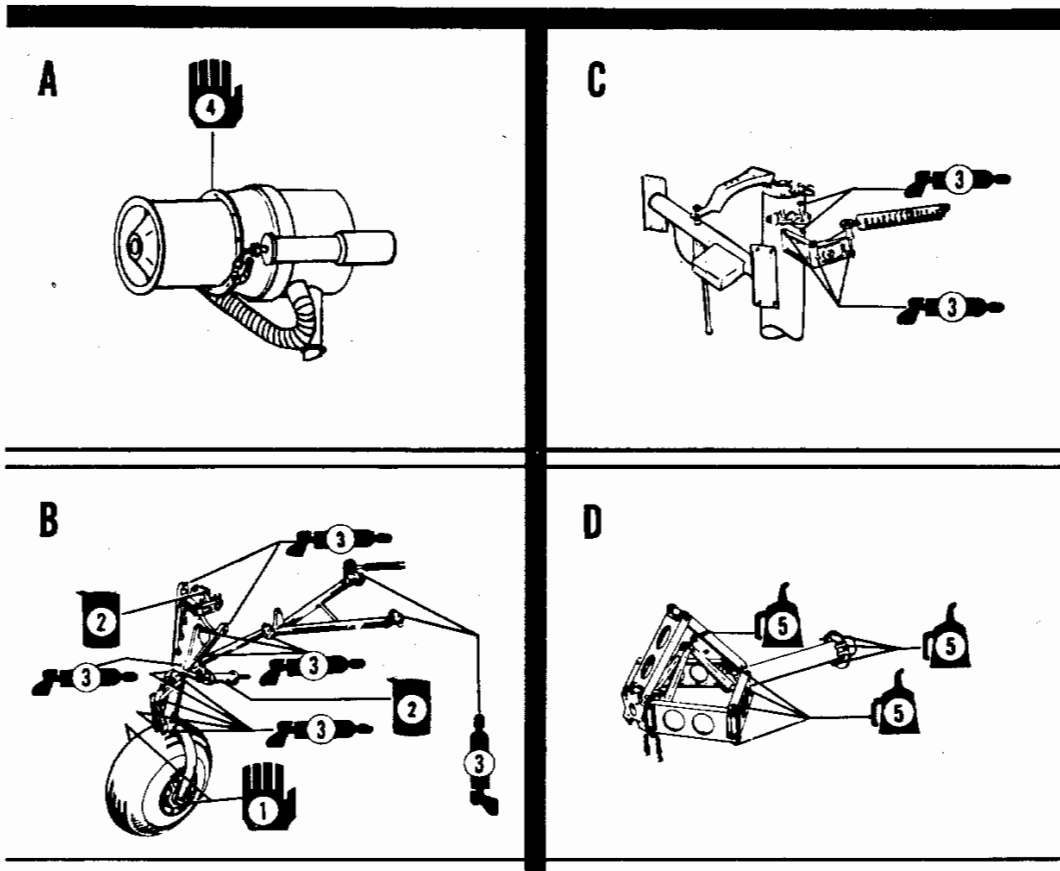
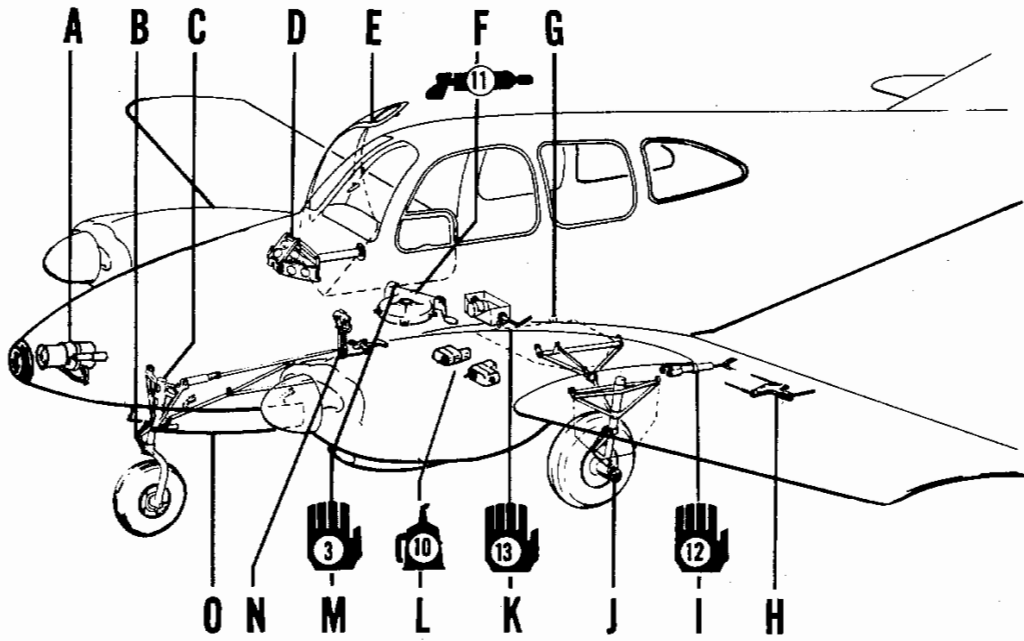



E

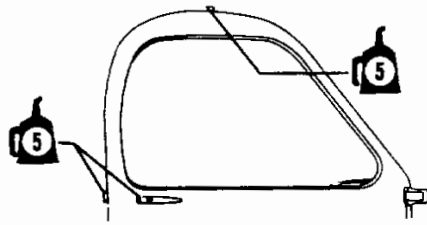

J

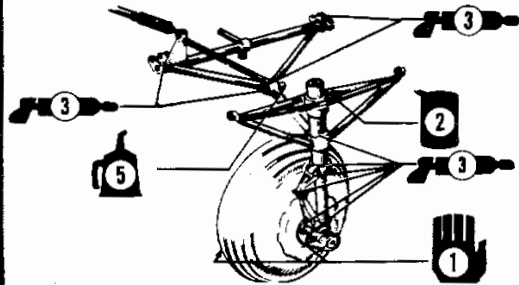

G

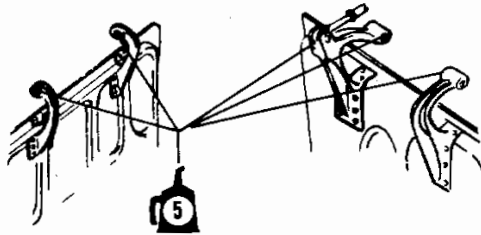

N



H

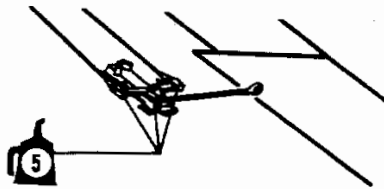

O

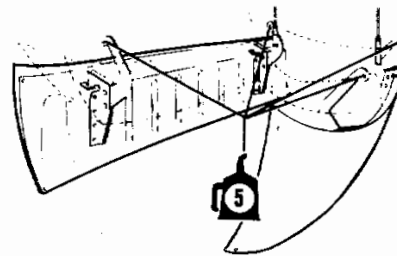

ZERK FITTING



HYDRAULIC FLUID



HAND OR PACK



SQUIRT CAN

Note:

Letters are keyed to the Service Schedule; numbers refer to items in the Consumable Materials Chart.

tion uses a special wheel design with no valve stem hole. Inflation is accomplished through a self sealing sidewall type valve in the tire. These tubeless tires cannot be used on tube-type wheels, nor can tube-type tires be used on wheels designed for sidewall inflating tires — the difference being either the absence, or presence of the tube valve stem hole in the wheel casting. Modification of these castings to include valve stem holes for converting tubeless tires to tube-type may be made if desired. Tube-type tires and wheels are standard equipment. Tubeless type tires are optional. Inflation of the tube-type tires is of course accomplished in the usual manner. A tubeless tire may be inflated as follows:

1. Lubricate the inflating needle. Use the lubricant provided with the needle.
2. Work the lubricant into and around the guide hole in the valve on the side of the tire.

#### **CAUTION**

The valve opening and needle should be well lubricated before the needle is inserted. Never insert the needle into a dry valve.

3. Insert the inflating needle into the tire filler valve opening with a rotating motion.

#### **CAUTION**

Do not *Force* the needle into the valve; relubricate as required.

4. Inflate the tire in the usual manner, to the appropriate pressure.
5. Remove the inflating needle immediately after inflating a tire.

Always store the inflation valve kit in its plastic protective cover.

Inflate both the 6.50-8 main wheel tires to 50 psi, and the 5.00-5 nose wheel tire to 50 psi. Either the tubeless or the tube-type tires are inflated to the same pressure. Maintaining proper tire inflation will minimize tread wear and aid in preventing tire rupture caused from running over sharp stones and ruts. When inflating tires, visually inspect them for cracks and breaks.

## **Heat and Vent System Maintenance**

The cabin heater ignition unit is equipped with two sets of points; when the first 1000-hour inspection of the airplane is performed, the heater electrical wiring is changed to place the alternate contact points in service. At the second 1000-hour inspection a new vibrator unit is installed. In this manner unused points are placed in service after each 1000 hours of airplane operation.

The over-heat fuse should not be replaced until a thorough inspection of the system has determined the cause of its blowing and the malfunction has been corrected.

After every 25 hours of heater operation, remove the heater fuel pump strainer in each heater fuel pump by turning the base of the pump counterclockwise. Wash the strainers in clean, unleaded gasoline and dry with compressed air.

A fuel filter is installed in the nose wheel well forward of the heater fuel pumps and filters foreign matter from the fuel. The filter is equipped with a snap type drain and should be drained daily during cold weather to remove accumulated moisture, which if allowed to freeze could cause heater malfunction.

Lubricate the iris valve at the blower inlet occasionally with Consumable Materials Chart Item 4, never with oil or any liquid lubricant which will collect dust.

## **Servicing the Battery**

To service the battery, open the forward utility compartment door and remove the battery box cover. Maintain the electrolyte level to cover the plates by adding distilled battery water. Avoid filling over the baffles and never fill more than one-quarter inch over the separator tops. Excessive water consumption may be an indication that the voltage regulators require resetting. The specific gravity should be checked periodically and maintained within the limits placarded on the battery. The battery box is vented overboard to dispose of electrolyte and hydrogen gas fumes discharged during the normal charging operation. To insure the disposal of these fumes, the vent hose connections at the battery box should be checked frequently for obstructions.

## **Air Intake Filters**

To clean the air intake filters, remove from the aircraft and flush

thoroughly with cleaning solvent; if possible, use an air blast for drying. After the filters are completely dry, saturate with clean engine oil and allow to drain before reinstallation.

## **Propellers**

Since propellers are subject to wear and atmospheric conditions, blades and hub should be periodically checked for oxidation and corrosion. Brush corroded or oxidized areas with a phosphatizing agent to remove superficial corrosion, then smooth etched and pitted areas by buffing (by hand) with an aluminum polish.

Take the following precautions while cleaning propellers:

1. Be sure ignition switch is off.
2. Make sure the engine has cooled down completely. When moving the propeller, **STAND IN THE CLEAR**. There always is some danger of a cylinder firing when a propeller is moved.
3. If a liquid cleaner is used, avoid using excessive amounts because it may spatter or run down the blade and enter the hub or engine.
4. After cleaning, check the area around the hub to be sure all compound is removed.

## **Servicing the Anti-Icer System (Optional)**

The purpose of the anti-icer system is to prevent the formation of ice on the propeller blades during flight. The prevention of icing is accomplished by wetting the blades with isopropyl alcohol. The system consists of a supply tank, pump with filter, quantity transmitter and indicator, slinger rings, circuit breaker, control switch, and anti-icer boots.

The anti-icer tank is located beneath the floor on the left hand side of the forward utility compartment. The tank has a capacity of 3 U. S. gallons of anti-icer fluid (see Consumable Materials Chart). The tank filler cap may be reached by removing an access door in the floor of the compartment upper section. Check the tank fluid level before each cold weather flight and refill if necessary. The tank should be drained and flushed twice a year.

## **Servicing the Deicer System (Optional)**

The Light Weight Deicer System in your Travel Air will be charged to a reservoir pressure of  $2800 \pm 200$  psi prior to delivery. Maximum operating pressure for the system is 3000 psi, charged with DRY, oil-free, compressed air or nitrogen.

Deicer boots installed on the leading edges of the wings and empennage are supplied with inflation pressure from the reservoir, which is mounted in the upper section of the forward utility compartment. The reservoir may be charged through a filler valve using any standard high pressure hose.

To service the reservoir, first remove the yellow safety cap on the reservoir filler valve and connect a high pressure charging line to the filler valve.

### **WARNING**

Never service the system with oxygen, explosive gases, or corrosive gases. Always observe the maximum pressure limitation of 3000 psi.

Turn the filler valve upper hex nut counterclockwise to open the interior seal and open the air supply valve on the instrument panel to admit reservoir pressure to the high pressure gages on the regulator and instrument panel. Charge the reservoir to  $2800 \pm 200$  psi, then turn the filler valve upper hex nut clockwise to set the interior seal, disengage the high pressure charging line, and replace the yellow cap on the filler valve.

Reservoir pressure may be observed by the pilot at any time by pulling out the shut-off valve control on the instrument panel and reading the pressure gage adjacent to the control. Check pressure before each cold weather flight and recharge the reservoir if necessary.

## **Servicing the Oxygen System (Optional)**

### **WARNING**

Keep hands, tools, clothing, and oxygen equipment clean and free from grease and oil. **KEEP FIRE AWAY FROM OXYGEN.**

1. Check cylinder pressure by slowly opening the shut-off valve on the oxygen console panel and noting the gage reading. (The shut-off valve on the oxygen cylinder must also be open.) If the oxygen cylinder is equipped with a gage, system pressure may be checked at the cylinder.

### **CAUTION**

Always open the shut-off valves slowly to prevent damage to the system.

2. Close all shut-off valves, remove the cap from the oxygen cylinder filler valve, and attach the recharging outlet.
3. Open the cylinder shut-off valve and fill the system to 1800 psi.
4. Close the cylinder shut-off valve, remove the recharging outlet, and replace the filler valve cap.
5. Reopen the cylinder shut-off valve to prepare the system for use.

### **Engine**

The engine may be cleaned with kerosene, white furnace oil, Stoddard solvent, or any standard engine cleaning solvent. Spray or brush the solvent over the engine, then wash off with water and allow to dry. Blow excess oil off the engine with compressed air.

### **Exterior Cleaning**

Prior to cleaning the exterior, cover the wheels, making certain the brake discs are covered. Attach pitot covers securely, and plug or mask off all other openings. Be particularly careful to mask off both static air buttons before washing or waxing.

### **CAUTION**

Do not apply wax or polish for a paint cure period of 90 days after delivery. Waxes and polishes seal the paint from the air and prevent curing. For uncured painted surfaces, wash only with cold or lukewarm (never hot) water and a *mild non-detergent soap*. Any rubbing of

the painted surface should be done gently and held to a minimum to avoid cracking the paint film.

The airplane should be washed with a mild soap and water. Loose dirt should be flushed away first with clean water. Harsh, abrasive or alkaline soaps or detergents which could cause corrosion or make scratches should never be used.

Soft cleaning cloths or a chamois should be used to prevent scratches when cleaning and polishing. Any ordinary automobile wax may be used to polish painted surfaces. To remove stubborn oil and grease, use a rag dampened with naphtha. However, after cleaning with naphtha, the surface should be rewaxed and polished.

### **Interior Cleaning**

The seats, rugs, upholstery panels, and head lining should be vacuum cleaned frequently to remove as much surface dust and dirt as possible. Commercial foam type cleaners or shampoos can be used to clean rugs, fabrics, or upholstery. However, be sure to follow the cleaner manufacturer's instructions.

### **Cleaning Windshield and Windows**

Since the plexiglass in the windshield and windows can be easily scratched, extreme care should be used in cleaning it. Never wipe the windshield or windows when dry. First, flush the surface with clean water or a mild soap solution, then rub lightly with a grit free soft cloth, sponge, or chamois. Use trisodium phosphate completely dissolved in water to remove oil and grease film. To remove stubborn grease and oil deposits use hectane, naphtha, or methanol. Rinse with clean water and avoid prolonged rubbing.

### **NOTE**

Do not use gasoline, benzine, acetone, carbon tetrachloride, fire extinguisher fluid, deicing fluid, or lacquer thinners on windshield or windows as they have a tendency to soften and craze the surface.

## INSPECTION

Correct servicing being half the secret of preventive maintenance, the other half is inspection. Proper servicing will prolong the life of your Travel Air and careful regular inspections will not only assure that servicing has been done correctly, but will disclose minor troubles so that they can be corrected before they become malfunctions. Patronize your BEEHCRAFT Certified Service Station. They are equipped and especially trained to service your Travel Air.

## LAMP REPLACEMENT GUIDE

LOCATION	NUMBER
Cabin Dome Light .....	303
Compass Light .....	327
Console Placard Lights .....	327
Cowl Flap Position Light .....	327
Flap Position Lights .....	327
Fuel Selector Panel Lights .....	327
Instrument Lights, Overhead .....	303
Instrument Lights, Post .....	327
Landing Gear Position Lights .....	327
Landing Gear Visual Indicator Light .....	356
Landing Light, Nose Cone .....	4596
Landing Light, Nose Gear .....	4523
L.H. Circuit Breaker and Switch Panel Lights .....	327
Map Light .....	303
Navigation Light, Tail .....	1203
Navigation Lights, Wing .....	1524
Rotating Beacon .....	A-7079A-24
Tab Indicator Red Light .....	1819R



## CONTROL SURFACE CHART

CABLES	CABLE TENSION	SURFACE TRAVEL
Aileron	25 lbs +5 -0 lbs	20° Up and Down $\pm 1^\circ$
Aileron Tab	10 lbs +5 -0 lbs	10° Up and Down $\pm 1^\circ$
Elevator	25 lbs +5 -0 lbs	30° Up, 15° Down $\pm 1^\circ$
Elevator Tab	15 lbs +5 -0 lbs	10° Up, 20° Down $\pm 1^\circ$
Rudder	25 lbs +5 -0 lbs	30° Lt. and 34° Rt. $\pm 1^\circ$
Rudder Tab	15 lbs +5 -0 lbs	25° Left and Right $\pm 1^\circ$
Flaps		28° Down +0° -2°

## CONSUMABLE MATERIALS CHART

ITEM	MATERIAL	SPECIFICATIONS	
1.	Lubricating Grease, High Temperature	MIL-G-3545	
2.	Hydraulic Fluid	MIL-H-5606	
3.	Lubricating Grease, (General Purpose)	MIL-G-7711	
4.	Molybdenum Disulfide	MIL-M-7866	
5.	Lubricating Oil	SAE No. 20	
6.	Engine Oil		
	Average Ambient Air Temperature for Starting	Single Viscosity Grade	Multi-Viscosity Grade
	Above 60°F	SAE 50	SAE 40 or SAE 50
	30° to 90°F	SAE 40	SAE 40
	0° to 70°F	SAE 30	SAE 40 or 20W-30
	Below 10°F	SAE 20	SAE 20W-30
7.	Fuel, Engine	Grade 91/96	
8.	Anti-Icing Fluid	MIL-F-5566	

*Chart Continues on Next Page*

## CONSUMABLE MATERIALS CHART (Cont.)

ITEM	MATERIAL	SPECIFICATIONS
9.	Solvent	Federal Specification, P-S-661
10.	Lubricant	Scintilla 10-86527
11.	Lubricating Grease	Mobil Compound GG
12.	Lubricating Oil, Gear	MIL-L-6086, Grade M
13.	Grease, Aircraft and Instrument	MIL-G-3278
14.	Thread Compound, Anti-Seize and Sealing, Oxygen Systems	MIL-T-5542
15.	Soap Solution, Oxygen System Leak Testing	MIL-S-4282
<b>NOTES</b>		
1. In extremely cold climates, MIL-G-3278 grease should be used in place of MIL-G-7711.		
2. Care should be exercised when using either MIL-G-7711 or MIL-G-3278 grease, as they contain a rust-preventing additive which is harmful to paint.		
3. All engine oils should conform to Lycoming Specification 301-E. See servicing notes on additive type oils.		
4. If 91/96 grade fuel is not available, 100/130 or 115/145 grade fuel may be used as an alternate. Never use 80/87 grade fuel.		

## **SAFETY MAINTENANCE SCHEDULE**

### **COMPONENT**

### **OVERHAUL OR REPLACE**

#### **LANDING GEAR**

Brake master cylinder	Every 1000 to 1200 hours.
Parking brake valve	Every 1000 hours.
Wheel brake assembly	Inspect at lining replacement.
Main gear assembly	Every 1000 hours.
Nose gear assembly	Every 1000 hours.
Shimmy dampener	Every 1000 hours.
Landing gear actuator assembly and motor	Every 1000 hours.

#### **WING FLAPS**

Flap motor and gearbox	Every 1000 hours.
Flap actuator	Every 1000 hours.

#### **POWER PLANT**

Engine	*Every 800 hours.
Propeller	To coincide with engine overhaul at 500 to 1000 hours.
Propeller governor	Every 1000 hours or at engine change due to internal engine failure.
Fuel injection regulator	At engine overhaul.
Oil cooler	Every 800 hours or at engine change due to internal engine failure.
Oil separator	At each engine overhaul or change.
Vacuum pump	At engine overhaul.
Magnetos	At engine overhaul.
Starter	At engine overhaul.
Generator	At engine overhaul.
All hose	Replace every 1000 hours or 5 years from date of manufacture.

\*Two extensions of 25% are permissible if the engine checks satisfactorily.

## SAFETY MAINTENANCE SCHEDULE (Contd.)

### COMPONENT

### OVERHAUL OR REPLACE

#### FUEL SYSTEM

Fuel selector valves	Every 1000 hours.
Auxiliary fuel pump	Every 1000 hours.
Fuel quantity transmitters	Replace when necessary.
Fuel check valves	Inspect every 24 months. Replace when necessary.
Fuel drain valves	Replace every 72 months.
All hose	Replace every 1000 hours or 5 years from date of manufacture.

#### ELECTRICAL SYSTEM

Landing gear dynamic brake relay	Replace every 1000 hours.
Battery master relay	Replace every 1000 hours.
Starter relay	Replace when necessary.
Starter vibrator	Replace when necessary.
Voltage regulator	Every 1000 hours.
Paralleling relay	Every 1000 hours.
Heater blower	Every 1000 hours.
Heater igniter	Replace after every 2000 hours of heater operation.

#### UTILITY SYSTEMS

Cabin heater	Overhaul and pressure test after every 500 hours of heater operation.
Heater fuel pump	Replace when defective.
Heater fuel shut-off valve	Every 12 months.
Deicer reservoir	As required.
Deicer cycling valve	As required.
Deicer regulator	As required.
Vacuum regulator	Replace when all vacuum driven in- struments operate erratically.

## SAFETY MAINTENANCE SCHEDULE (Contd.)

### COMPONENT

### OVERHAUL OR REPLACE

#### UTILITY SYSTEMS (Contd.)

Propeller anti-icer pump	Every 1000 hours.
Oxygen regulator	Every 800 hours or 24 months.
Oxygen cylinder	Every 5 years.
All hose	Replace every 1000 hours or 5 years from date of manufacture.

#### INSTRUMENTS

Manifold pressure gage	Every 1000 hours or 24 months.
Cylinder head temperature gage	Every 1000 hours or 24 months.
Oil pressure gage	Every 1000 hours or 24 months.
Oil temperature gage	Every 1000 hours or 24 months.
Fuel flow indicator	Every 1000 hours or 24 months.
Fuel quantity indicator	Replace when necessary.
Airspeed indicator	Every 1000 hours or 24 months.
Altimeter	Every 1000 hours or 24 months.
Rate-of-climb indicator	Every 1000 hours or 24 months.
Directional gyro	Every 600 hours or 14 months.
Attitude gyro	Every 600 hours or 14 months.
Tachometer (single)	Replace when necessary.
Tachometer (dual)	Every 1500 hours.
Suction gage	Every 1000 hours or 24 months.
Ammeters	Replace when necessary.
Magnetic compass	Replace when necessary.
Clock	Overhaul when necessary.
Turn-and-bank indicator	Every 600 hours or 14 months.
Propeller anti-icer gage	Replace when necessary.
Deicer pressure gage	Every 1000 hours or 24 months.
All hose	Replace every 1000 hours or 5 years from date of manufacture.

# TOPICAL INDEX

	Page
<b>A</b>	
Air Intake Filters .....	7-17
Airspeed Charts .....	3-2
Airspeed Limitations .....	3-3
Anti-Icer, Propeller .....	4-14
Servicing the System .....	7-18
<b>B</b>	
Balked Landing .....	5-12
Battery, Servicing the .....	7-17
<b>BEECHCRAFT</b>	
Certified Service .....	7-1
Parts and Service Operations ...	7-3
Service Publications .....	7-2
<b>Before</b>	
Landing Check .....	2-4
Starting Check .....	2-3
Take-off Check .....	2-4
Belts, Safety .....	1-16
Brakes, Servicing the .....	7-10
<b>C</b>	
Cabin Interior .....	1-17
Certified Service, BEECHCRAFT .....	7-1
<b>Check</b>	
Before Landing .....	2-4
Before Take-off .....	2-4
Before Starting .....	2-3
Shutdown .....	2-4
Starting .....	2-3
Climb .....	4-5
<b>Cleaning</b>	
Exterior .....	7-20
Interior .....	7-21
Windshield and Windows .....	7-21
Cold Weather Operation .....	4-12
Consumable Materials Chart .....	7-23
<b>Controls</b>	
Flight .....	1-2
Power Plant .....	1-5
Control Surface Chart .....	7-23
Control Tower Visibility .....	1-15
Cross Feed, Single Engine Operation	
on .....	5-9
<b>Crosswind</b>	
Landing .....	5-11
Take-off .....	5-10
Cruise .....	4-6
<b>D</b>	
Data, Operational .....	6-1
Deicer, Surface .....	4-14
Duration Table .....	3-5
Servicing the System .....	7-19
Descent .....	4-10
<b>E</b>	
Electrical System .....	1-10
Emergency Extension, Landing Gear	5-12
<b>Engine</b>	
Cleaning .....	7-20
Determining Inoperative .....	5-4
Failure During Flight .....	5-7
Failure During Take-off .....	5-5
Fire in Flight .....	5-13
Go-Around, Single .....	5-9
Instrument Markings .....	3-4
Landing, Single .....	5-8
Operation Single .....	5-1
Operation Limitations .....	3-4
Out Procedure, Simulated One ..	5-2
Procedure, Normal Single .....	5-5
Restarting Inoperative .....	5-7
Shutdown .....	4-12
Starting .....	2-3, 4-2
Warm-up .....	4-3
Equipment, Optional .....	1-20
Extension, Landing Gear Emergency	5-12
Exterior Cleaning .....	7-20
External Power .....	4-13, 7-5
<b>F</b>	
Filters, Air Intake .....	7-17
Fire in Flight, Engine .....	5-13
Flap and Landing Gear Indicators ..	1-16
Flight Controls .....	1-2
Flight, Instrument .....	4-17
Fuel System .....	1-6
Servicing the .....	7-8
<b>G</b>	
Gear Up Landing .....	5-12
Gear, Landing .....	1-2
Glare Shield, Instrument Panel ...	1-17
Glide, Maximum .....	5-13
Gliding Distance Table .....	3-5
Graph, Use of the Zero Thrust .....	5-3
Ground Handling .....	7-3
<b>H</b>	
Handling, Ground .....	7-3
Heat and Vent System Maintenance	7-17
Heating and Ventilating System ...	1-12

	Page
<b>I</b>	
Indicators, Landing Gear and Flaps	1-16
Indicator, Stall Warning	1-16
Inspection	7-22
Exterior	4-1
Preflight	2-2
Instrument Flight	4-17
Instrument Panel Glare Shield	1-17
Instruments	1-8
Interior Cleaning	7-21

<b>J</b>	
Jacking, Main Wheel	7-4

<b>K</b>	
Kit, Your Service Information	7-3

<b>L</b>	
Lamp Replacement Guide	7-22
Landing Gear	1-2
And Flap Indicators	1-16
Emergency Extension	5-12
Servicing the	7-9
Landing Lights	1-16
Landing	
Balked	5-12
Crosswind	5-11
Gear Up	5-12
Lights	1-16
Night	4-11
Normal	4-11
Obstacle	5-11
Single Engine	5-8
Lubrication Chart	7-14

<b>M</b>	
Magnetos	7-5
Maintenance	
Preventive	7-1
Schedule, Safety	7-25
Maneuvers	3-6, 4-9
Materials Chart, Consumable	7-23

<b>O</b>	
Obstacle	
Landing	5-11
Take-off	5-10
Oil System	1-8
Servicing the	7-6
Operation	
From Unimproved Field	5-10
On Crossfeed, Single Engine	5-9
Single Engine	5-1
Cold Weather	4-12

	Page
Operational Data	6-1
Optional Equipment	1-20
Oxygen System	
Duration Table	3-6
Operation	4-16
Servicing	7-19

<b>P</b>	
Parts and Service Operations,	
BEECHCRAFT	7-3
Power, External	4-13, 7-5
Power Plants	1-4
Power Plant Controls	1-5
Preflight Inspection	2-2
Propellers	7-18
Publications, BEECHCRAFT Service	7-2

<b>R</b>	
Restarting Inoperative Engine	5-7

<b>S</b>	
Safety	
Belts	1-16
Maintenance Schedule	7-25
Service	
BEECHCRAFT Certified	7-1
Bulletins and Service Letters	7-2
Information Kit	7-3
Publications, BEECHCRAFT	7-2
Schedule	7-12
Servicing	
The Anti-Icer System	7-18
The Battery	7-17
The Brakes	7-10
The Deicer System	7-19
The Fuel System	7-8
The Landing Gear	7-9
The Oil System	7-6
The Oxygen System	7-19
Tubeless Tires	7-10
Shutdown Check	2-4
Shutdown, Engine	4-12
Single Engine	
Go-around	5-9
Landing	5-8
Procedure, Normal	5-5
Operation	5-1
Operation on Cross Feed	5-9
Speeds	
Climb	3-2
Landing	3-3
Stall	3-3
Take-off	3-2
Stall Warning Indicator	1-16
Starting	4-2

	Page
Check System .....	2-3
Electrical .....	1-10
Fuel .....	1-6
Heating and Ventilating .....	1-12
Oil .....	1-8
Servicing the Anti-Icer .....	7-18
Servicing the Deicer .....	7-19
Servicing the Fuel .....	7-8
Servicing the Oil .....	7-6
Servicing the Oxygen .....	7-19
Vacuum .....	1-14

### T

Take-off	
Crosswind .....	5-10
Normal .....	4-4
Obstacle .....	5-10
Taxiing .....	4-3
Tires, Servicing Tubeless .....	7-10
Towing .....	7-4

	Page
Turbulent Air, Flight Through .....	4-10

### V

Vacuum System .....	1-14
Ventilating and Heating System .....	1-12
Visibility, Control Tower .....	1-15

### W

Warm-up, Engine .....	4-3
Warning Indicator, Stall .....	1-16
Weather Operation, Cold .....	4-12
Weight and Balance .....	3-6
Windshield and Windows, Cleaning .....	7-21

### Y

Your Service Information Kit .....	7-3
------------------------------------	-----

### Z

Zero Thrust Graph, Use of the .....	5-3
-------------------------------------	-----